

PowerTrax™
LINEAR SYSTEMS
AND COMPONENTS

Excel™ SELF-ALIGNING
LINEAR BEARINGS
& PILLOW BLOCKS

LINEAR SYSTEMS AND COMPONENTS

TECHNICAL INTRODUCTION 219-228

- Linear Ball Bearing, Shafting, Pillow Block and Slide System Features 221-222
- Bearing Design Considerations 223-225
- System Design Considerations 226-227
- Application Examples 227-228

EXCEL™ INCH SELF-ALIGNING BEARINGS AND PILLOW BLOCKS 229-233

- Inch EXCEL™ Closed and Open Bearings 230
- Inch EXCEL™ Single Closed and Open Pillow Blocks 231
- Inch EXCEL™ Twin Closed and Open Pillow Blocks 232
- Inch Flanged Mount Single and Twin Pillow Block 233

POWERTRAX™ LBB BEARINGS 234-238

- LBB Precision Closed and Open Bearings 234-235
- Stainless Steel Bearings 236
- Instrument Bearings and Shafting 237
- Seal Specifications 238

LUBRICATION 239

PRECISION HARDENED AND GROUND SHAFTING 240-243

- Inch Precision Hardened Shafting 240
- Nook Shaft - Precut/Stocked Shafting 243
- Precision End Machining 244

SUPPORT RAILS AND SUPPORT BLOCKS 244-246

- Low Profile 244
- Standard Profile 245
- Shaft Support Blocks 246

SLIDE SYSTEMS & ACCESSORIES 247-259

- Series 100, 200 & MM Slide™ 247
- Reference Number System 248
- Carriage Plates 249
- Series 121, 131, 112, 122, 132, 113, 123 and 133 Slide Systems 249-253
- Series 212 and 252 254-255
- Series 302 and 312 Slide System 256-257
- MM Slide™ System 258
- Motor Adapters and Bellows Boots 259

METRIC EXCEL™ SELF-ALIGNING BEARINGS, PILLOW BLOCKS AND PRECISION LINEAR SHAFTING 260-262

- EXCEL™ Closed and Open Bearings 260
- EXCEL™ Single and Twin Closed Pillow Blocks 261
- Metric Precision Linear Shafting 262



The specifications and data in this publication are believed to be accurate and reliable. However, it is the responsibility of the product user to determine the suitability of Nook Industries products for a specific application. While defective products will be replaced without charge if promptly returned, no liability is assumed beyond such replacement.

PowerTrax™ Linear Systems and Components

**POWERTRAX™
TECHNICAL DATA**

LINEAR COMPONENTS TECHNICAL INTRODUCTION

PowerTrax™
PRECISION LINEAR SYSTEMS,
COMPONENTS, & SHAFTING

Excel™ SELF-ALIGNING
LINEAR BEARINGS
& PILLOW BLOCKS





LINEAR BEARING TYPES AND LINEAR SHAFTING

POWERTRAX™ TECHNICAL DATA

Nook Industries manufactures a full range of linear slide systems and slide systems components. The PowerTrax™ line of linear components includes solid shell LBB linear bearings, self-aligning EXCEL™ linear bearings, HG Hardened and Ground Shafting, Pillow Blocks and complete slide systems.

LINEAR BEARING TYPES

EXCEL™ LINEAR BEARINGS

Designed to fit into precision bores, these bearings are self aligning and offer long life. Precision hardened and ground bearing plates with conforming ball tracks are contained in a molded thermoplastic housing.

LBB

These bearings are used in lower load applications where self alignment is not required. The precision fit between the bearing and shaft is built into the bearing as a result of the solid steel shell. These bearings utilize a molded plastic ball retainer assembled inside a hardened and ground shell.

ILBB INSTRUMENT SERIES

Similar in construction to LBB linear bearings, Instrument Series Linear Bearings are small diameter, high precision bearings with stainless steel shells. When matched with Instrument Series Linear Shafting, ILBB Linear Bearings provide high performance with .0001 to .0003 inch clearances.

ILBB Linear Bearings are used in light load, high precision applications where low friction guidance is required such as medical and semiconductor equipment.

OPEN SERIES BEARINGS

For applications requiring fully supported shafts, "open" bearings

are available in both LBB and EXCEL™ types. In an open bearing, one ball circuit is removed to allow the mounted bearing to translate along a supported shaft.

SEALS

LBB and EXCEL™ bearings are available in sealed and unsealed versions. ILBB bearings are unsealed.

MATERIALS

Nook PowerTrax™ linear bearings use a combination of high performance thermoplastic, chrome-steel bearing balls, and either a one piece hardened steel shell or precision ground hardened steel bearing plates. (SEE FIG. 1)

EXCEL™ MAXIMUM SPEED

When used in high speed or high impact environments, EXCEL™ bearing capacities should be de-rated as shown in the chart. Divide the rated load by the load factor to determine the appropriate bearing size. (SEE FIG. 2)

LINEAR SHAFTING

MATERIAL

Nook PowerTrax™ HG Shafting, made from high quality alloy steel, is manufactured and stocked for immediate shipment in our Cleveland, Ohio facility, in diameters from 5 to 80mm and 1/4 to 4 inches. Stainless Steel shafting is available from 1/4 thru 2 inch diameter.

Standard diameters can be cut to your specified length and shipped within 24 hours of receipt of your order. Contact Nook Industries, Inc. for availability of special diameters.

CASE HARDNESS

PowerTrax™ HG alloy shafting is induction hardened to Rc 60-63. Stainless steel shafting is hardened to Rc 50-55. Instrument Series Shafting is hardened to Rc 55-60. The case depth on all PowerTrax™ HG Shafting is precisely controlled for optimal performance. The extremely hard surface minimizes wear and is resistant to nicks and scratches. (SEE FIG. 3 on following page)

LINEAR COMPONENTS TECHNICAL INTRODUCTION

FIG. 1

	OUTER SHELL	BALLS	BEARING PLATE	BALL RETAINER	END RINGS	INTERNAL SEALS
EXCEL™ SELF-ALIGNING	Plastic Resin NYLON-66	Hardened Chrome Steel	Hardened Steel	N/A	N/A	Nitrile
LBB SERIES	Hardened Steel Black Oxide	Hardened Chrome Steel	N/A	Acetal Resin	Steel Black Oxide	Nitrile
STAINLESS STEEL SERIES	Stainless Steel	Hardened Chrome Steel	N/A	Acetal Resin	Stainless Steel	N/A
INSTRUMENT SERIES	440C	440C	N/A	Acetal Resin	Stainless Steel	N/A

FIG. 2

IMPACTS & VIBRATIONS	SPEED	ACCELERATION (G)	LOAD FACTOR (f)
Without external impacts or vibrations	Velocity ≤ 50 ft/min	Acceleration < 0.5G	1 ~ 1.5
Without significant impacts or vibrations	Velocity > 50 ft/min and ≤ 190 ft/min	Acceleration > 0.5G and ≤ 1.0G	1.5 ~ 2.0
Without external impacts or vibrations	Velocity > 190 ft/min	Acceleration > 1.0G and ≤ 2.0G	2.0 ~ 3.5

The specifications and data in this publication are believed to be accurate and reliable. However, it is the responsibility of the product user to determine the suitability of Nook Industries products for a specific application. While defective products will be replaced without charge if promptly returned, no liability is assumed beyond such replacement.

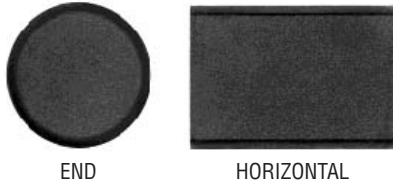

FIG. 3

HARDENED SHAFT CROSS SECTION**SURFACE FINISH**

PowerTrax™ HG shafting is centerless ground to a consistently smooth surface finish of 14 micro-inches rms or less. Excellent surface finish and hardness maximize the efficiency and life of linear bearings.

STRAIGHTNESS

PowerTrax™ HG shafts are straight within 0.002 of an inch per foot cumulative when shipped from the factory. Handling or machining of shafting can cause the material to bend.

PREDRILLED & TAPPED HOLES

PowerTrax™ HG alloy shafting is stocked with radial holes drilled and tapped to accept a continuous shaft support rail. Continuous support prevents shaft deflection when used to support heavy loads or for long travel lengths. Radial holes can be supplied in stainless steel shafts from 1/2" to 2" diameter.

PRECISION END MACHINING

PowerTrax™ HG shafting can be supplied pre-machined to application requirements. Send a detailed sketch or blueprint for a prompt quotation. See page 212 for descriptions of machining offered by Nook Industries. Templates for machining are available on our website—www.nookindustries.com

**LENGTH TOLERANCE**

PowerTrax™ HG shafting cut to your specified length will have a standard length tolerance of +1/32" up to 2" and ±1/16 above. Closer tolerances are available for an additional charge. Non-precision chamfered ends are standard on all cut shafting.

SHAFT SUPPORTS

Aluminum support components for end mounting or continuously supporting PowerTrax™ HG shafting are available for inch sizes 1/2" to 2".

**SELF-ALIGNING PILLOW BLOCKS**

PowerTrax™ Pillow Blocks simplify mounting of PowerTrax™ Linear Bearings. They are available with EXCEL™ Bearings to fit shafts from 1/4 to 2 inch and 10 to 50mm. PowerTrax™ Pillow Blocks provide the precision bearing bores necessary for linear bearing installation.

MOUNTING TOLERANCES

The PowerTrax™ Pillow Block mounting surface to centerline dimension is held to ±0.001 inch. Bearings will self-align up to ±1/2°.

MATERIALS

All PowerTrax™ Pillow Blocks are manufactured from precision machined, thick walled, extruded aluminum.

PILLOW BLOCK SEALS

PowerTrax™ Pillow Blocks are supplied complete with lip seals. The sealed pillow block keeps lubricant in and dirt and debris out resulting in smoother operation and longer bearing life.

LINEAR SLIDE SYSTEMS**SERIES 100 SLIDE SYSTEMS**

PowerTrax™ Series 100 slide systems are pre-assembled and ready to mount. Series 100 slides consist of combinations of PowerTrax™ Linear Ball Bearing Pillow Blocks, HG shafting, carriage plates and shaft supports. Aluminum carriage plates include threaded steel inserts at key mounting locations.

SERIES 200 SLIDE SYSTEMS

PowerTrax™ Series 200 slide systems are assembled slides which include:

- Linear bearing pillow blocks
- Integrated end supports
- HG linear shafts
- Carriage Plate
- PowerTrax™ Ball Screw assembly

Many options are available for these slide systems. Different screw styles and leads, protective boots, special motor mounts and custom carriage plate machining is available. Contact Nook Industries, Inc. for assistance.

MM SLIDE™**MINI SLIDE SYSTEMS**

PowerTrax™ MM Slides™ are metric-dimensioned compact slide units. They utilize lightweight aluminum components and include an integrated carriage/pillow block assembly for a reduced overall height. A wide variety of screw diameters, leads and nut styles are available. These systems include:

- EXCEL™ linear bearings
- Integrated end supports
- HG linear shafts
- Carriage/pillow block assembly
- 1 Lead screw assembly



BEARING DESIGN CONSIDERATIONS

LINEAR COMPONENTS TECHNICAL INTRODUCTION

BEARING DESIGN CONSIDERATIONS

APPLICATION VARIABLES

To determine the best linear bearing product or system for your application it is necessary to know:

- Amount of load
- How the load is applied
- Length of stroke

COEFFICIENT OF FRICTION

PowerTrax™ linear bearings exhibit an extremely low coefficient of friction ranging from 0.0008 to 0.0035. Coefficients of static and rolling friction are used to estimate the force required to overcome frictional resistance.

The formulas for determining static and rolling frictional resistance are:

Static Friction:
 $F_s = L \times f_s$

Rolling Friction:
 $F_d = L \times f_d$

WHERE:

F_s = Static frictional resistance (lbs)

F_d = dynamic frictional resistance (lbs)

L = applied radial load (pounds)

f_s = coefficient of static friction

f_d = coefficient of rolling friction

The tables show the coefficients of friction for PowerTrax™ Linear Bearings operating on hardened and ground shafts of recommended diameters. (SEE FIG. 4)

There are other variables that affect the dynamic frictional resistance of linear bearings. These variables include:

Lubrication – Dry linear bearings exhibit the lowest coefficient of friction. Friction values for

lubricated bearings are higher due to the presence of lubricant surface tension.

Seals – Non-linear seal drag occurs because of the geometry and the materials used in the bearing seals.

Contamination – Foreign particles restrict free rolling of the bearing balls and will contribute to an increase in dynamic frictional resistance.

LUBRICATION

A lubricant formulated for rolling friction should be used with PowerTrax™ Linear Bearings.

In applications where operating speeds are low and loads are light, PowerTrax™ linear bearings can be used without lubrication at a reduced life. However, to protect the highly polished bearing surfaces from corrosion and wear, a lubricant is recommended.

Where linear speeds are high, a light oil should be used and provision for re-lubrication should be made to avoid operating the bearings dry. For typical applications, a medium to heavy oil has good surface adhesion and affords greater bearing protection.

Linear Bearings 2" diameter and above may use high pressure

lithium grease such as Shell Alvania #2 for moderate speed applications. Lubricants containing additives such as molydisulfide or graphite should not be used.

Nook Linear Lube LBL-1 liquid is a good, all purpose lubricant for use with linear bearings. See page 239 for more information.

MAXIMUM AND NORMAL LOAD RATINGS

The required design life, the shaft hardness, and a bearing dynamic load rating affect the load that can be applied to a PowerTrax™ linear bearing. Two dynamic load ratings are given for each bearing size based on the rotational orientation of the bearing.

Normal Load Rating – The Normal Load Rating is used in applications where the orientation of the ball tracks relative to the load cannot be controlled. The Normal load rating is based on a load imposed directly over a single ball track. The Normal load rating shown in the specification tables is slightly greater than would be mathematically calculated based on one track loading because it assumes that the load is shared to some degree by one or more of the adjacent ball tracks.

FIG. 4 Coefficients of Static Friction (f_s)

TYPE OF BEARING LUBRICATION	LOAD IN % OF RATED LOAD			
	100%	75%	50%	25%
ANY	.0024	.0026	.0029	.0035

Coefficients of Rolling Friction (f_d)

TYPE OF BEARING LUBRICATION	LOAD IN % OF RATED LOAD			
	100%	75%	50%	25%
NONE	.0008	.0009	.0013	.0018
OIL	.0012	.0013	.0016	.0021
GREASE	.0013	.0015	.0019	.0026

The specifications and data in this publication are believed to be accurate and reliable. However, it is the responsibility of the product user to determine the suitability of Nook Industries products for a specific application. While defective products will be replaced without charge if promptly returned, no liability is assumed beyond such replacement.



BEARING DESIGN CONSIDERATIONS

LINEAR COMPONENTS TECHNICAL INTRODUCTION

Maximum Load Rating –

The Maximum load rating assumes that the load is applied midway between two ball tracks as illustrated below. In this orientation the load is distributed over the maximum number of bearing balls.

(SEE FIG. 5).

FIG. 5

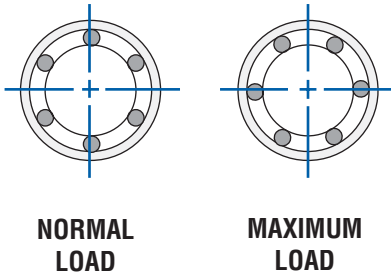

LOAD LIFE DETERMINATION

The Normal and Maximum load ratings are based on a Rc 60 shaft hardness and a travel life of two million inches.

For linear bearing system operating at less than full rated load, the Load-Life Curve may be used to determine the travel life expectancy.

(SEE FIG. 6)

SHAFT HARDNESS

If shafting other than standard alloy PowerTrax™ HG shafting is used, the Shaft Hardness Curve establishes a shaft hardness correction factor, Rh. When calculating the equivalent load, this factor compensates for the effect of hardness. (SEE FIG. 7)

EQUIVALENT LOAD

An equivalent load value can be calculated when sizing linear bearings for applications at conditions other than maximum rating.

Equivalent Load Formula:

$$L_e = L_a / (R_L \times R_h)$$

WHERE:

L_e = Dynamic Equivalent Load (The minimum bearing capacity to meet design life requirements)

L_a = Applied Load (Actual Load)

R_L = Load Life Ratio Factor (from chart)

R_h = Shaft Hardness Ratio Factor (from chart)

BEARING INSTALLATION

In most installations, PowerTrax™ linear ball bearings are designed to slip-fit into the housing bore and secured by one of the following means:

Between an internal housing shoulder and a threaded cap.

Between external retaining rings.

Between internal snap rings in the bore of the housing.

The bore diameter required to maintain recommended bearing/shaft clearance is given in the EXCEL™ linear bearing information section. The bore does not affect clearance between an LBB bearing and a shaft. (SEE FIG. 8)

FIG. 8

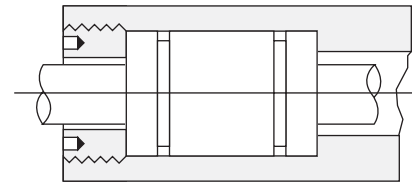

Between an internal housing shoulder and a threaded cap.

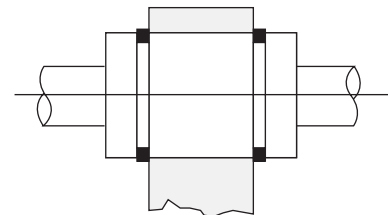

Between external retaining rings.

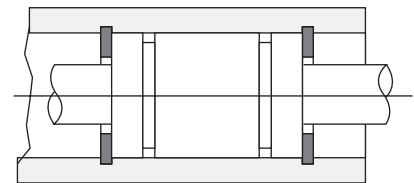

Between internal snap rings in the bore of the housing.

FIG. 6

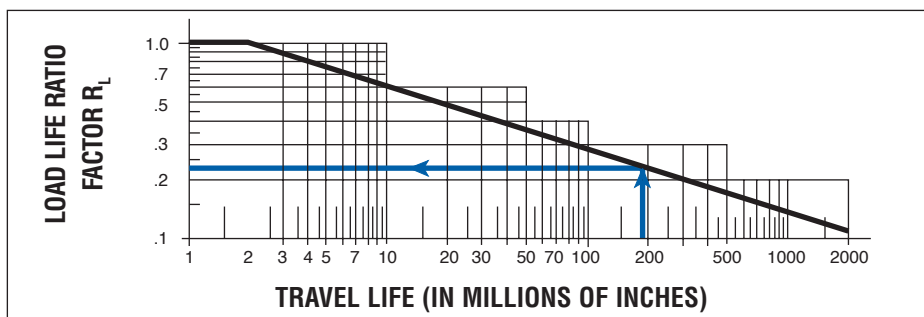
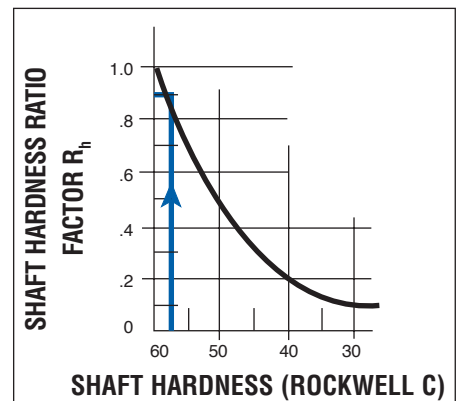

FIG. 7



ASSEMBLY EXCESSIVE FIT

Oversized shaft diameters or misalignment between the installed bearings can cause preload between the shaft and the bearing. Preload conditions should be corrected before operating the bearing. If, in an assembled unit, the shaft can freely rotate relative to the bearing, then the fit is at the maximum or less.

SYSTEM DESIGN CONSIDERATIONS

SYSTEM CONFIGURATION

PowerTrax™ Linear Slide Systems are available in a variety of configurations. The following factors should be considered when choosing the slide system which best suits an application.

SINGLE OR DOUBLE SHAFT SYSTEMS

The majority of applications require double shaft systems in order to restrain the load in two planes. Single shaft systems may be used for hanging or vertical loads where rotation of the bearing around the shaft is allowable.

FULLY SUPPORTED OR UNSUPPORTED SHAFTS

Fully supported systems are used to eliminate shaft deflection. Full shaft supports must be attached to a machined mounting base. Open-style bearings used with this system are sensitive to load orientation.

End-supported systems are generally used to span a gap or where some deflection is allowable. This system uses closed-style bearings that achieve higher load capacities. The shaft must be selected so that deflection does not exceed self-alignment capability of the bearing.

LINEAR BEARING PILLOW BLOCKS

Two bearings must be used to support a load on a shaft. Single blocks allow for custom spacing and wider load bearing stances. Twin pillow blocks have a compact, one-piece design.

CARRIAGE PLATES

Carriage plates are designed in two styles for linear system packages. Carriage 1 is designed for two pairs of single bearing blocks. Carriage 2 is designed for two twin bearing blocks and has a shorter over all length.

BEARING/SHAFT SIZE

For fully supported systems the bearing size needed for the application is determined by the load and life requirements.

For end-supported systems, both the bearing diameter that meets load and life requirements and the shaft diameter that results in an allowable deflection must be determined. The correct choice of shaft/bearing diameter is the larger of the two.

LOAD CONDITIONS

Linear systems require at least three bearings to define the plane of motion. It is necessary to identify and understand which of following load conditions affect the application:

- Centered Loads
- Offset loads
- Side Loads
- Vertical Loads
- Gravity effects
- Reaction Forces (i.e., cutting tool reaction).
- Dynamic loading (acceleration, deceleration and inertial loads)



Apply the actual load to the appropriate load condition in the figure below to calculate the resulting bearing loads. (SEE FIG. 10).

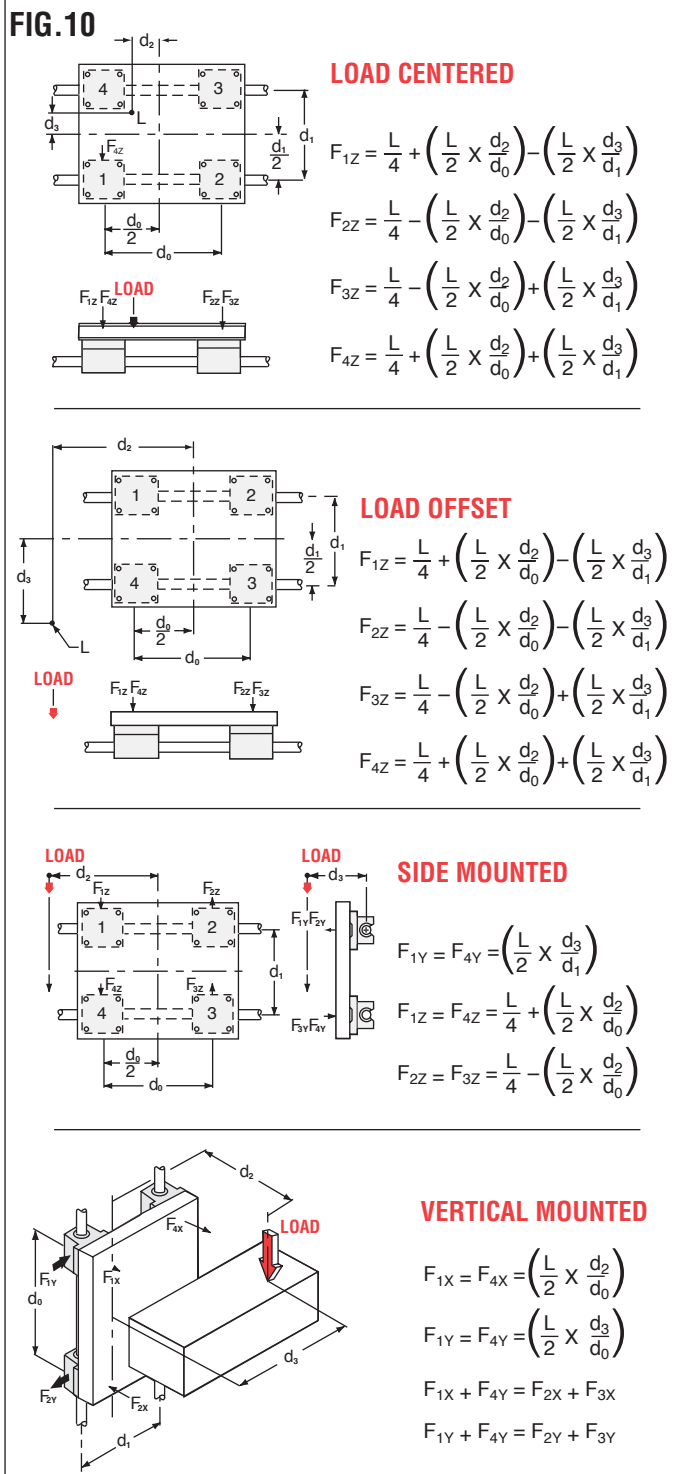

ACCELERATION FORCES

Use the equation in the following figure to determine the additional forces developed due to acceleration. If impact or impulse loads are anticipated, these forces must also be considered when selecting the appropriate bearing size. (SEE FIG. 11)

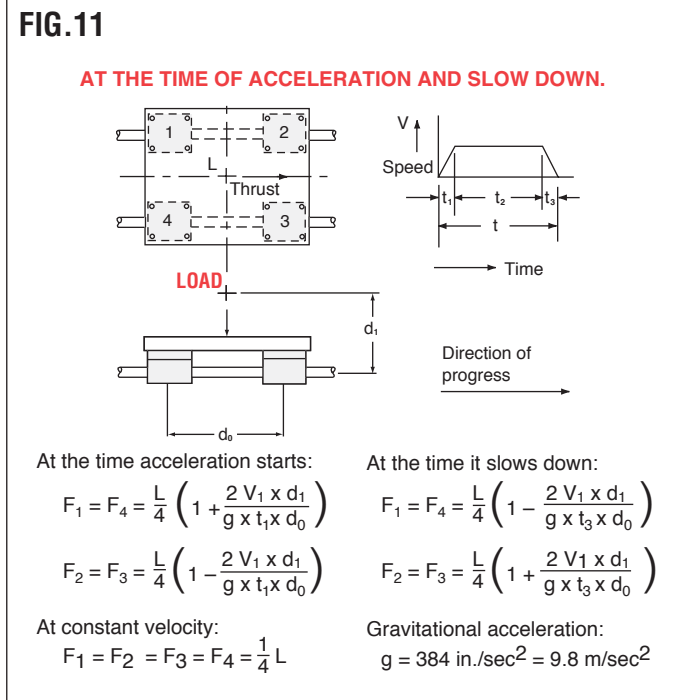

SHAFT DEFLECTION

Shaft deflection should be considered when choosing the proper bearing and shaft diameter for end-supported systems. Deflection is directly related to the diameter of the shaft, the unsupported length of the shaft, and the type of shaft end mounting that is used.

Typical Shaft End Mounting. (SEE FIG. 12)

“Simple” - the end allows some of the shaft deflection slope through the fastening point.

“Fixed” - the ends are constrained from deflection.

NOTE: Fixed end mounting can be accomplished by capturing the shaft end with a length of engagement equal to or greater than 1 1/2 times the shaft diameter.

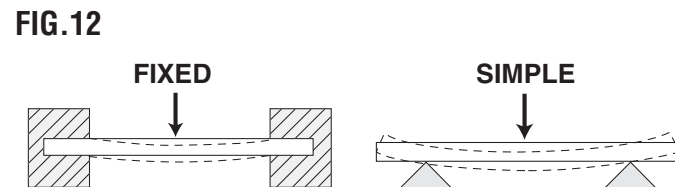

DEFLECTION CALCULATION

Use the formula:

$$D = N \times W \times L^3$$

WHERE:

N = value from fig.13

W = load in pounds

L = length (in inches) of unsupported shaft section

CALCULATE MISALIGNMENT ANGLE

PowerTrax™ linear bearings allow for 1/2 degree misalignment. To determine the amount of misalignment due to shaft deflection use the formula:

$$\theta = \sin^{-1} (D/L)$$

WHERE:

θ = angle in degrees

D = shaft deflection

L = length (in inches) of unsupported shaft section.

If misalignment is greater than 1/2 degree, then:

- Reduce the Length of the shaft.
- Use a larger shaft diameter.

FIG.13

"N" VALUE FOR NOOK SHAFTS		
SHAFT DIAMETER (in.)	SIMPLE	FIXED
1/4	3620 x 10 ⁻⁹	905 x 10 ⁻⁹
3/8	715 x 10 ⁻⁹	179 x 10 ⁻⁹
1/2	226 x 10 ⁻⁹	56.6 x 10 ⁻⁹
3/4	44.7 x 10 ⁻⁹	11.2 x 10 ⁻⁹
1	14.1 x 10 ⁻⁹	3.54 x 10 ⁻⁹
1-1/2	2.79 x 10 ⁻⁹	.698 x 10 ⁻⁹
2	0.866 x 10 ⁻⁹	.0220 x 10 ⁻⁹
3	0.168 x 10 ⁻⁹	.432 x 10 ⁻¹⁰
4	0.052 x 10 ⁻⁹	.136 x 10 ⁻¹⁰

APPLICATION EXAMPLES

Application #1 – PACKAGING LINE

An appliance manufacturer needs to move products in boxes so that they can be presented to a transfer conveyor after final assembly.

Specifications:

- The boxes weigh 200 pounds
- The unit reciprocates 8 times per minute
- 4.5 inch stroke
- 365 days per year, ten year design life.
- Slightly corrosive environment

What is the proper size EXCEL™ Bearing which will satisfy this application?

ANALYSIS:

Configuration: There is enough space available for four linear bearings. The system will use stainless steel shafting with a hardness of Rc 55. The load can be centered between four standard Excel™ linear bearings

Travel Life:

4.5 in./stroke x 8 strokes/min. x 60 min./hr x
24 hrs/day x 365 days/year x 10 years
= 189,000,000 inches.

Load-Life Ratio Factor (R_L): Based on the computed travel life and the load-life curve $R_L = .22$.

Shaft Hardness Ratio Factor (R_H):

For PowerTrax™ HG Stainless shafting with a hardness of Rc 55, $R_H = .70$.

Applied Load (L_a): Per bearing, $L_a = 200/4 = 50$ lbs.

Equivalent Load (L_e): Substituting in the load formula and solving for $L_e = 50 / (.22 \times .70) = 325$ pounds

SELECTION:

From the EXCEL™ Bearing load tables, the smallest bearing which exceeds this load rating is the 3/4 inch bearing. However, if the application is such that the bearing could be oriented for maximum capacity, then the 5/8 inch bearing could be used.

The Parts List Is:

- 4 XLEC12 EXCEL™ Linear bearings
- 2 PowerTrax™ HG Stainless shafting, 9.25 inch minimum length
- 2 PowerTrax™ NSB-12 End supports



Application #2 – SCANNER POSITIONING

A vision system scanner is mounted to the center of the carriage of a vertically mounted slide system. The customer wants to use one inch open pillow blocks to guarantee a long life.

Specifications:

- Scanner weight is 100 pounds
- The center of gravity is offset 4 inches from the carriage plate
- The adjustment distance is 36 inches
- Minimal deflection desired
- Hand adjustment with future automation planned
- A travel life of 10 million inches is desired

ANALYSIS:

Configuration: A standard system with carriage plate and fully supported shafts will assure minimal deflection.

Load per Bearing: The load is centered and offset four inches. Use the equations from the load condition figure “Vertically Mounted” to determine the worst case force through a bearing. The distance from the load to the centerline of the shaft (d_2) is $4 + 1.187$ or 5.187 inches. The bearing spacing (d_0) is set by the carriage plate; $d_0 = 7$ inches. Based on a design factor of 2, the load per bearing is 74 pounds. This is far below the rated value of a one inch open bearing.

NOTE: When using open-style bearings, if the direction of loading force is through the opening of the bearing, it is necessary to de-rate the bearing capacity by 50%.

SELECTION:

PowerTrax™ Series 133 consisting of a double shaft fully supported system with Carriage 1 and four (4) single bearing blocks.

The Parts List Is:

133-16-L36

FIG.14

LOAD / LIFE

Lines indicate limiting load for given shaft size

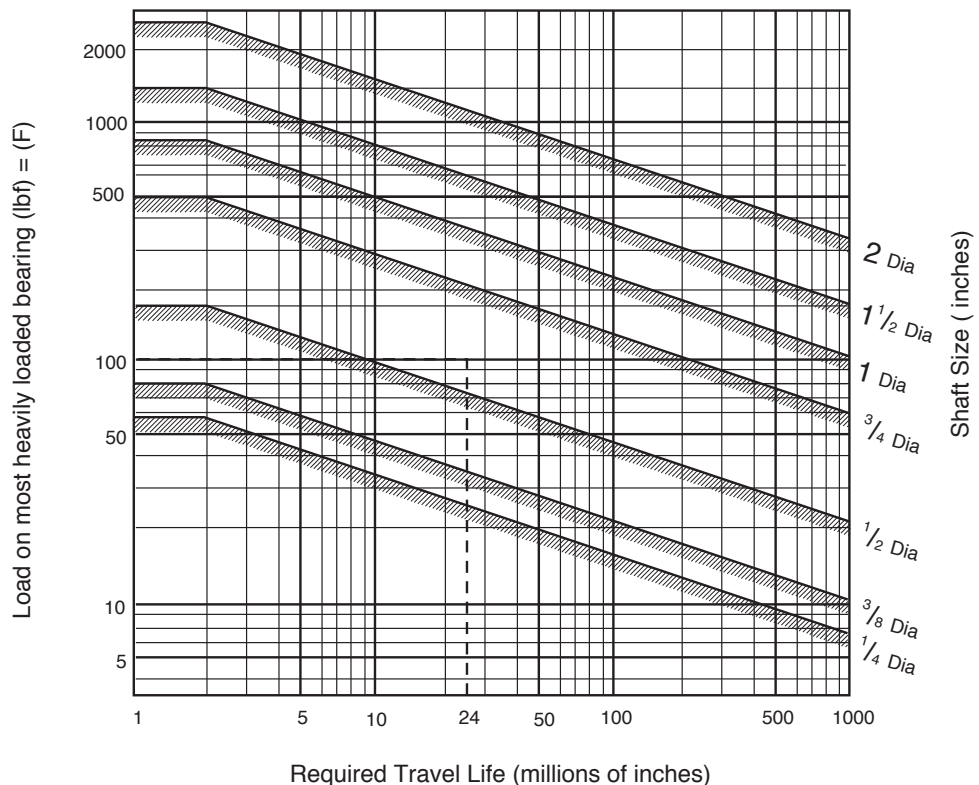
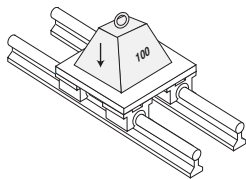



EXCEL™ SELF-ALIGNING BEARINGS AND POWERTRAX™ LBB BEARINGS

EXCEL™ BEARINGS

EXCEL™ LINEAR BEARINGS

Designed to fit into precision bores, these bearings are self aligning and offer long life. Precision hardened and ground bearing plates with conforming ball tracks are contained in a molded thermoplastic housing.

LBB

These bearings are used in lower load applications where self alignment is not required. The precision fit between the bearing and shaft is built into the bearing as a result of the solid steel shell. These bearings utilize a molded plastic bearing ball retainer assembled inside a hardened and ground shell.

ILBB INSTRUMENT SERIES

Similar in construction to LBB linear bearings, Instrument Series Linear Bearings are small diameter, high precision bearings with stainless steel shells. When matched with Instrument Series Linear Shafting, ILBB Linear Bearings provide high performance with .0001 to .0003 inch clearances.

ILBB Linear Bearings are used in light load, high precision applications where low friction guidance is required such as medical and semiconductor equipment.



EXCEL™ INCH SELF-ALIGNING BEARINGS AND PILLOW BLOCKS TECHNICAL DATA

The specifications and data in this publication are believed to be accurate and reliable. However, it is the responsibility of the product user to determine the suitability of Nook Industries products for a specific application. While defective products will be replaced without charge if promptly returned, no liability is assumed beyond such replacement.



EXCEL™ INCH SELF-ALIGNING BEARINGS AND PILLOW BLOCKS TECHNICAL DATA

INCH - CLOSED BEARINGS



- Designed for use on end supported PowerTrax™ HG “L” shafting.
- Bearings are available with or without shaft seals.

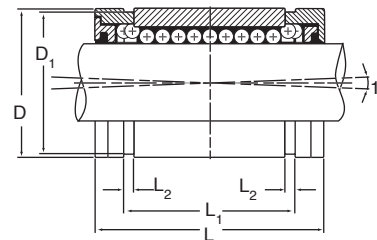

Nominal Shaft Dia.	EXCEL™ Without Seal	EXCEL™ With Seal	No. of Ball Circuits	Housing Bore Dia. D	D ₁	L	L ₁	L ₂	Dynamic Load (lb.)		Static Load (lb.)	
									Normal	Maximum	Normal	Maximum
1/4"	XLEC04	XLEC04UU	4	0.5005/0.5000	0.4687	0.750/0.735	0.511/0.501	0.039	39	45	27	38
3/8"	XLEC06	XLEC06UU	4	0.6255/0.6250	0.5880	0.875/0.860	0.699/0.689	0.039	59	68	43	61
1/2"	XLEC08	XLEC08UU	4	0.8755/0.8750	0.8209	1.250/1.230	1.032/1.012	0.050	152	175	112	158
5/8"	XLEC10	XLEC10UU	5	1.1255/1.1250	1.0700	1.500/1.480	1.105/1.095	0.056	273	325	187	273
3/4"	XLEC12	XLEC12UU	6	1.2505/1.2500	1.1760	1.625/1.605	1.270/1.250	0.056	383	406	274	351
1"	XLEC16	XLEC16UU	6	1.5630/1.5625	1.4900	2.250/2.230	1.884/1.864	0.070	684	725	492	630
1 1/4"	XLEC20	XLEC20UU	6	2.0008/2.0000	1.8890	2.625/2.600	2.004/1.984	0.068	1017	1078	712	911
1 1/2"	XLEC24	XLEC24UU	6	2.3760/2.3750	2.2389	3.000/2.970	2.410/2.390	0.086	1298	1376	852	1091
2"	XLEC32	XLEC32UU	6	3.0010/3.0000	2.8379	4.000/3.960	3.193/3.163	0.105	2104	2230	1458	1866

INCH - OPEN BEARINGS



- Designed for use on fully supported PowerTrax™ HG “L” shafting.
- Longitudinal section equal to one ball circuit removed for support rail clearance.
- Standard bearing includes shaft seals.

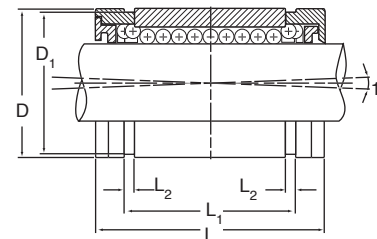

Nominal Shaft Dia.	EXCEL™ With Seal	No. of Ball Circuits	Housing Bore Dia. D	D ₁	L	L ₁	L ₂	E	Dynamic Load (lb.)		Static Load (lb.)	
									Normal	Maximum	Normal	Maximum
1/2"	XLEN08UU	3	0.8755/0.8750	0.8209	1.250/1.230	1.032/1.012	0.050	0.32	152	152	112	112
5/8"	XLEN10UU	4	1.1255/1.1250	1.0700	1.500/1.480	1.105/1.095	0.056	0.38	315	318	229	236
3/4"	XLEN12UU	5	1.2505/1.2500	1.1760	1.625/1.605	1.270/1.250	0.056	0.43	386	398	279	312
1"	XLEN16UU	5	1.5630/1.5625	1.4900	2.250/2.230	1.884/1.864	0.070	0.56	690	711	501	561
1 1/4"	XLEN20UU	5	2.0008/2.0000	1.8890	2.625/2.600	2.004/1.984	0.068	0.63	1025	1056	726	813
1 1/2"	XLEN24UU	5	2.3760/2.3750	2.2389	3.000/2.970	2.410/2.390	0.086	0.75	1307	1346	867	971
2"	XLEN32UU	5	3.0010/3.0000	2.8379	4.000/3.960	3.193/3.163	0.105	1.00	2121	2185	1485	1663

* DO NOT exceed 1/2 of rated values when load is applied through the bearing opening.

INCH - CLOSED SINGLE PILLOW BLOCKS



- Sealed at both ends, contains a closed unsealed EXCEL™ Bearing.
- Designed for use on end supported PowerTrax™ HG “L” shafting.

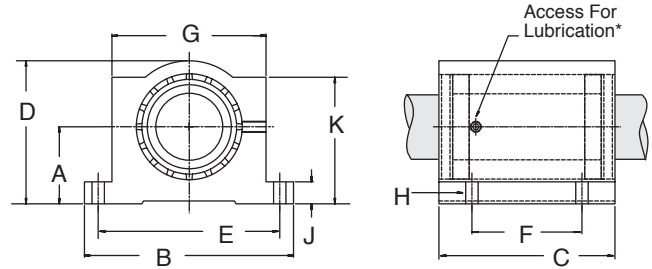

* Lubrication holes for blocks up to 1/2" have flush lube fitting; 5/8" and above are 1/4 – 28 tapped hole with set screw

Nominal Shaft Dia.	EXCEL™ Part No.	A ±0.001	B	C	D	E ±0.005	F ±0.005	G	H		J	K	Weight lbs.	Dynamic Load (lb.)		Static Load (lb.)	
									Bolt	Hole				Normal	Maximum	Normal	Maximum
3/8"	XEP-06	0.500	1 3/4"	1 5/16"	1 5/16"	1.437	0.875	1 1/8"	#6	0.17	3/16"	7/8"	0.12	59	68	43	61
1/2"	XEP-08	0.687	2"	1 11/16"	1 1/4"	1.688	1.000	1 3/8"	#6	0.17	1/4"	1 1/8"	0.20	152	175	112	158
5/8"	XEP-10	0.875	2 1/2"	1 15/16"	1 5/8"	2.125	1.125	1 3/4"	#8	0.19	9/32"	1 7/16"	0.50	273	325	187	273
3/4"	XEP-12	0.937	2 3/4"	2 1/16"	1 3/4"	2.375	1.250	1 7/8"	#8	0.19	5/16"	1 9/16"	0.60	383	406	274	351
1"	XEP-16	1.187	3 1/4"	2 13/16"	2 3/16"	2.875	1.750	2 3/8"	#10	0.22	3/8"	1 15/16"	1.20	684	725	492	630
1 1/4"	XEP-20	1.500	4"	3 5/8"	2 13/16"	3.500	2.000	3"	#10	0.22	7/16"	2 1/2"	2.50	1017	1078	712	911
1 1/2"	XEP-24	1.750	4 3/4"	4"	3 1/4"	4.125	2.500	3 1/2"	1/4"	0.28	1/2"	2 7/8"	3.80	1298	1376	852	1091
2"	XEP-32	2.125	6"	5"	4 1/16"	5.250	3.250	4 1/2"	3/8"	0.41	5/8"	3 5/8"	7.00	2104	2230	1458	1866

INCH - OPEN SINGLE PILLOW BLOCKS



- Sealed at both ends, contains an open, sealed EXCEL™ Bearing.
- Designed for use with fully supported PowerTrax™ HG “L” shafting
- Longitudinal section equal to one ball circuit removed for support rail clearance.

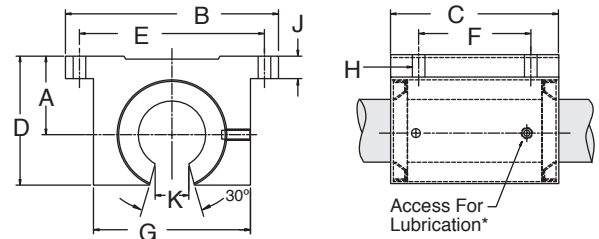

* Lubrication holes for blocks up to 1/2" have flush lube fitting; 5/8" and above are 1/4 – 28 tapped hole with set screw

Nominal Shaft Dia.	EXCEL™ Part No.	A ±0.001	B	C	D	E ±0.005	F ±0.005	G	H		J	K	Weight lbs.	Dynamic Load (lb.)		Static Load (lb.)	
									Bolt	Hole				Normal	Maximum	Normal	Maximum
1/2"	XEP-08-OPN	0.687	2"	1 1/2"	1 1/8"	1.688	1.000	1 3/8"	#6	0.17	1/4"	5/16"	0.20	152	152	112	112
5/8"	XEP-10-OPN	0.875	2 1/2"	1 3/4"	1 7/16"	2.125	1.125	1 3/4"	#8	0.19	9/32"	3/8"	0.40	315	318	229	236
3/4"	XEP-12-OPN	0.937	2 3/4"	1 7/8"	1 9/16"	2.375	1.250	1 7/8"	#8	0.19	5/16"	7/16"	0.50	386	398	279	312
1"	XEP-16-OPN	1.187	3 1/4"	2 5/8"	1 15/16"	2.875	1.750	2 3/8"	#10	0.22	3/8"	9/16"	1.00	690	711	501	561
1 1/4"	XEP-20-OPN	1.500	4"	3 3/8"	2 1/2"	3.500	2.000	3"	#10	0.22	7/16"	5/8"	2.10	1025	1056	726	813
1 1/2"	XEP-24-OPN	1.750	4 3/4"	3 3/4"	2 7/8"	4.125	2.500	3 1/2"	1/4"	0.28	1/2"	3/4"	3.20	1307	1346	867	971
2"	XEP-32-OPN	2.125	6"	4 3/4"	3 5/8"	5.250	3.250	4 1/2"	3/8"	0.41	5/8"	1"	6.00	2121	2185	1485	1663

* DO NOT exceed 1/2 of rated values when load is applied through the bearing opening.



EXCEL™ INCH SELF-ALIGNING BEARINGS AND PILLOW BLOCKS TECHNICAL DATA

INCH - CLOSED TWIN PILLOW BLOCKS



- Sealed at both ends, contains two closed unsealed EXCEL™ Bearings.
- Designed for use on end supported PowerTrax™ HG “L” shafting.

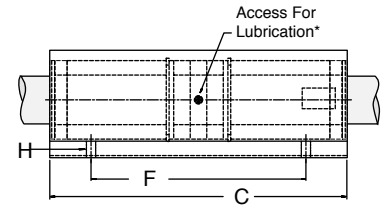
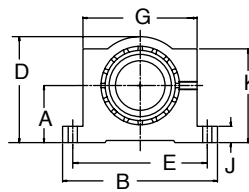

* Lubrication holes for blocks up to 1/2" have flush lube fitting; 5/8" and above are 1/4 – 28 tapped hole with set screw

Nominal Shaft Dia.	EXCEL™ Part No.	A ±0.001	B	C	D	E ±0.005	F ±0.005	G	H		J	K	Weight lbs.	Dynamic Load (lb.)		Static Load (lb.)	
									Bolt	Hole				Normal	Maximum	Normal	Maximum
3/8"	TEP-06	0.500	1 3/4"	2 3/4"	1 5/16"	1.437	2.250	1 1/8"	#6	0.17	3/16"	7/8"	0.25	118	136	86	122
1/2"	TEP-08	0.687	2"	3 1/2"	1 1/4"	1.688	2.500	1 3/8"	#6	0.17	1/4"	1 1/8"	0.40	304	350	224	316
5/8"	TEP-10	0.875	2 1/2"	4"	1 5/8"	2.125	3.000	1 3/4"	#8	0.19	9/32"	1 7/16"	1.00	546	650	374	546
3/4"	TEP-12	0.937	2 3/4"	4 1/2"	1 3/4"	2.375	3.500	1 7/8"	#8	0.19	5/16"	1 9/16"	1.20	766	812	548	702
1"	TEP-16	1.187	3 1/4"	6"	2 3/16"	2.875	4.500	2 3/8"	#10	0.22	3/8"	1 15/16"	2.40	1368	1450	984	1260
1 1/4"	TEP-20	1.500	4"	7 1/2"	2 13/16"	3.500	5.500	3"	#10	0.22	7/16"	2 1/2"	5.00	2034	2156	1424	1822
1 1/2"	TEP-24	1.750	4 3/4"	9"	3 1/4"	4.125	6.500	3 1/2"	1/4"	0.28	1/2"	2 7/8"	7.80	2596	2752	1704	2182
2"	TEP-32	2.125	6"	10"	4 1/16"	5.250	8.250	4 1/2"	3/8"	0.41	5/8"	3 5/8"	14.50	4208	4460	2916	3732

INCH - OPEN TWIN PILLOW BLOCKS



- Sealed at both ends, contains two open, sealed EXCEL™ Bearings.
- Designed for use with fully supported PowerTrax™ HG “L” shafting.
- Longitudinal section equal to one ball circuit removed for support rail clearance.

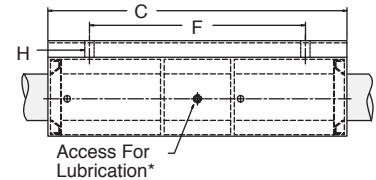
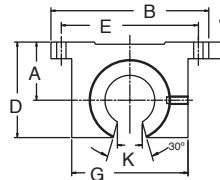

* Lubrication holes for blocks up to 1/2" have flush lube fitting; 5/8" and above are 1/4 – 28 tapped hole with set screw

Nominal Shaft Dia.	EXCEL™ Part No.	A ±0.001	B	C	D	E ±0.005	F ±0.005	G	H		J	K	Weight lbs.	Dynamic Load (lb.)		Static Load (lb.)	
									Bolt	Hole				Normal	Maximum	Normal	Maximum
1/2"	TEP-08-OPN	0.687	2"	3 1/2"	1.13	1.688	2.500	1 3/8"	#6	0.17	1/4"	5/16"	0.40	304	304	224	224
5/8"	TEP-10-OPN	0.875	2 1/2"	4"	1.44	2.125	3.000	1 3/4"	#8	0.19	9/32"	3/8"	0.80	630	636	458	472
3/4"	TEP-12-OPN	0.937	2 3/4"	4 1/2"	1.56	2.375	3.500	1 7/8"	#8	0.19	5/16"	7/16"	1.00	772	796	558	624
1"	TEP-16-OPN	1.187	3 1/4"	6"	1.94	2.875	4.500	2 3/8"	#10	0.22	3/8"	9/16"	2.00	1380	1422	1002	1122
1 1/4"	TEP-20-OPN	1.500	4"	7 1/2"	2.50	3.500	5.500	3"	#10	0.22	7/16"	5/8"	4.20	2050	2112	1452	1626
1 1/2"	TEP-24-OPN	1.750	4 3/4"	9"	2.88	4.125	6.500	3 1/2"	1/4"	0.28	1/2"	3/4"	6.70	2614	2692	1734	1942
2"	TEP-32-OPN	2.125	6"	10"	3.63	5.250	8.250	4 1/2"	3/8"	0.41	5/8"	1"	12.50	4242	4370	2970	3326

* DO NOT exceed 1/2 of rated values when load is applied through the bearing opening.



EXCEL™ PILLOW BLOCKS: FLANGE-MOUNT SINGLE & TWIN

**EXCEL™
BEARINGS**

INCH - FLANGE-MOUNT SINGLE AND TWIN PILLOW BLOCKS

EXCEL™ Linear Bearings provide high efficiency and smooth operation in a variety of linear guidance applications. EXCEL™ Flange-Mount Pillow Blocks offer an installation alternative to standard foot-mount pillow blocks when the mounting surface is perpendicular to the guide shafts. Nook Industries flanged mount pillow blocks are available in both single and twin bearing

styles and include 1/2 , 3/4 or 1 inch EXCEL™ Linear Bearings. The blocks have integral lip seals, an aluminum housing and a lubrication port. Typical applications include: platform guidance, end stop support, conveyor width adjust mechanisms, edge guides and machine operator guards.



- Sealed at both ends, contains unsealed EXCEL™ Bearing (two bearings in twin).
- Designed for use on end supported PowerTrax™ HG "L" shafting.

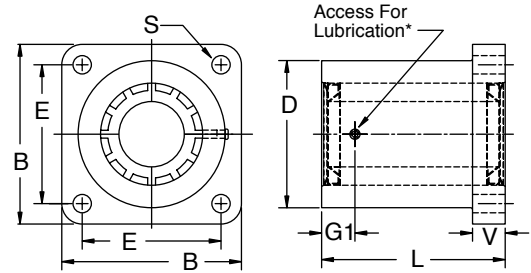

	Nominal Shaft Dia.	EXCEL™ Part No.	B	E ±0.005	L	D	V	G1	S Hole Dia.	DYNAMIC LOAD (lb.)		STATIC LOAD (lb.)	
										Normal	Maximum	Normal	Maximum
SINGLE	1/2"	XEP-08-FLM	1.63	1.250	1.69	1.25	0.25	0.35	0.19	152	175	112	158
	3/4"	XEP-12-FLM	2.38	1.750	2.06	1.75	0.38	0.37	0.22	383	406	274	351
	1"	XEP-16-FLM	2.75	2.125	2.81	2.25	0.50	0.51	0.28	684	725	492	630
Thread													
TWIN	1/2"	TEP-08-FLM	1.63	1.250	3.20	1.25	0.90	1.60	1/4-20	304	350	224	316
	3/4"	TEP-12-FLM	2.38	1.750	3.95	1.75	0.90	1.60	1/4-20	766	812	548	702
	1"	TEP-16-FLM	2.75	2.125	5.33	2.25	0.90	2.70	5/16-18	1368	1450	984	1260



The specifications and data in this publication are believed to be accurate and reliable. However, it is the responsibility of the product user to determine the suitability of Nook Industries products for a specific application. While defective products will be replaced without charge if promptly returned, no liability is assumed beyond such replacement.

LBB SERIES LINEAR BEARINGS

INCH - LBB PRECISION CLOSED BEARINGS



- Designed for use on end supported PowerTrax™ HG “L” shafting
- Solid steel shell, no seals

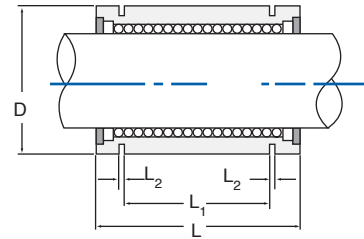

LBB LINEAR BEARINGS TECHNICAL DATA

Nominal Shaft Dia.	LBB Bearing Part Number	D	L	L ₁	L ₂	Weight (lb.)	Dynamic Load (lb.)	Static Load (lb.)
1/4"	LBB-250	0.5000/0.4996	.750	.437	.040	.02	25	27
3/8"	LBB-375	0.6250/0.6246	.875	.562	.040	.04	38	36
1/2"	LBB-500	0.8750/0.8746	1.250	.875	.047	.11	88	79
5/8"	LBB-625	1.1250/1.1246	1.500	1.00	.058	.22	160	139
3/4"	LBB-750	1.2500/1.2496	1.625	1.062	.058	.26	204	191
1"	LBB-1000	1.5625/1.5621	2.250	1.625	.070	.50	371	353
1 1/4"	LBB-1250	2.0000/1.9995	2.625	1.875	.070	.91	724	712
1 1/2"	LBB-1500	2.3750/2.3745	3.000	2.250	.088	1.44	948	831
2"	LBB-2000	3.0000/2.9994	4.000	3.000	.105	2.78	1,391	1,434

INCH - LBB PRECISION CLOSED SEALED BEARINGS



- Designed for use on end supported PowerTrax™ HG “L” shafting
- Solid steel shell with lip seals

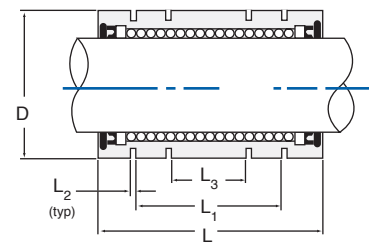

Nominal Shaft Dia.	LBB Bearing Part Number	D	L	L ₁	L ₂	L ₃	Weight (lb.)	Dynamic Load (lb.)	Static Load (lb.)
1/4"	LBB-250PP	0.5000/0.4996	.750	.437	.040	—	.03	25	27
3/8"	LBB-375PP	0.6250/0.6246	.875	.562	.040	—	.05	38	36
1/2"	LBB-500PP	0.8750/0.8746	1.438	.875	.047	.531	.12	88	79
5/8"	LBB-625PP	1.1250/1.1246	1.688	1.000	.058	—	.24	160	139
3/4"	LBB-750PP	1.2500/1.2496	1.875	1.062	.058	.687	.29	204	191
1"	LBB-1000PP	1.5625/1.5621	2.500	1.625	.070	.844	.52	371	353
1 1/4"	LBB-1250PP	2.0000/1.9995	3.125	1.875	.070	1.031	1.12	724	712
1 1/2"	LBB-1500PP	2.3750/2.3745	3.438	2.250	.088	1.219	1.62	948	831
2"	LBB-2000PP	3.0000/2.9994	4.750	3.000	.105	1.531	3.08	1,391	1,434

INCH - LBB PRECISION OPEN BEARINGS



- Designed for use on fully supported PowerTrax™ HG “L” shafting
- Longitudinal section equal to one ball circuit removed for support rail clearance.
- Solid steel shell, with no seals.

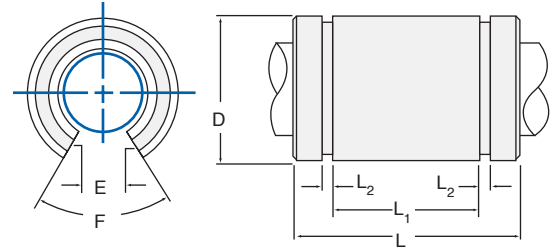

Nominal Shaft Dia.	LBB Bearing Part Number	D	L	L ₁	L ₂	E	F	Weight (lb.)	Dynamic Load (lb.)	Static Load (lb.)
1/2"	OPN-500	0.8750/0.8746	1.250	.875	.047	9/32	60°	.11	88	79
5/8"	OPN-625	1.1250/1.1246	1.500	1.000	.058	3/8	60°	.22	160	139
3/4"	OPN-750	1.2500/1.2496	1.625	1.062	.058	13/32	60°	.26	204	236
1"	OPN-1000	1.5625/1.5621	2.250	1.625	.070	9/16	60°	.50	445	438
1 1/4"	OPN-1250	2.0000/1.9995	2.625	1.875	.070	5/8	50°	.91	724	726
1 1/2"	OPN-1500	2.3750/2.3745	3.000	2.250	.088	3/4	50°	1.44	948	845
2"	OPN-2000	3.0000/2.9994	4.000	3.000	.105	1	50°	2.78	1,391	1,461

LBB LINEAR BEARINGS TECHNICAL DATA

INCH - LBB PRECISION OPEN SEALED BEARINGS



- Designed for use on fully supported PowerTrax™ HG “L” shafting
- Longitudinal section equal to one ball circuit removed for support rail clearance.
- Solid steel shell, with lip seals.

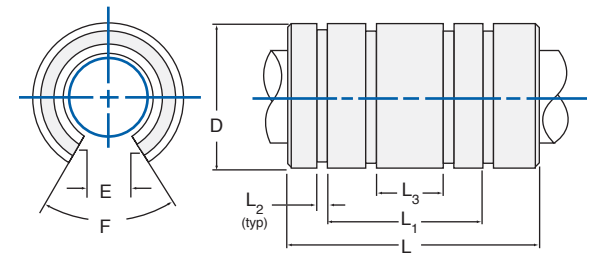

Nominal Shaft Dia.	LBB Bearing Part Number	D	L	L ₁	L ₂	L ₃	E	F	Weight (lb.)	Dynamic Load (lb.)	Static Load (lb.)
1/2"	OPN-500PP	0.8750/0.8746	1.438	.875	.047	.531	9/32	60°	.12	88	79
5/8"	OPN-625PP	1.1250/1.1246	1.688	1.000	.058	—	3/8	60°	.24	160	139
3/4"	OPN-750PP	1.2500/1.2496	1.875	1.062	.058	.687	13/32	60°	.29	204	236
1"	OPN-1000PP	1.5625/1.5621	2.500	1.625	.070	.844	9/16	60°	.52	445	438
1 1/4"	OPN-1250PP	2.0000/1.9995	3.125	1.875	.070	1.031	5/8	50°	1.12	724	726
1 1/2"	OPN-1500PP	2.3750/2.3745	3.438	2.250	.088	1.219	3/4	50°	1.62	948	845
2"	OPN-2000PP	3.0000/2.9994	4.750	3.000	.105	1.531	1	50°	3.08	1,391	1,461

The specifications and data in this publication are believed to be accurate and reliable. However, it is the responsibility of the product user to determine the suitability of Nook Industries products for a specific application. While defective products will be replaced without charge if promptly returned, no liability is assumed beyond such replacement.

INCH - LBB STAINLESS STEEL CLOSED BEARINGS



- Designed for use on an end supported PowerTrax™ HG "SL" shafting
- Solid stainless steel shell, no seals

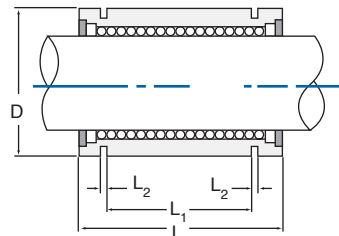

LBB LINEAR BEARINGS TECHNICAL DATA

Nominal Shaft Dia.	LBB Bearing Part Number	D	L	L ₁	L ₂	Weight (lb.)	Normal Load (lb.)	Max Load (lb.)
1/4"	LBB-250SS	0.5000/0.4996	.750	.437	.40	.02	17	25
3/8"	LBB-375SS	0.6250/0.6246	.875	.562	.404	.04	35	50
1/2"	LBB-500SS	0.8750/0.8746	1.250	.875	.047	.10	71	101
5/8"	LBB-625SS	1.1250/1.1246	1.500	1.000	.058	.22	126	179
3/4"	LBB-750SS	1.2500/1.2496	1.625	1.062	.058	.25	143	203
1"	LBB-1000SS	1.5625/1.5621	2.250	1.625	.070	.49	270	385

INCH - LBB STAINLESS STEEL OPEN BEARINGS



- Designed for use on a fully supported PowerTrax™ HG "SL" shafting.
- Longitudinal section equal to one ball circuit removed for support rail clearance.
- Solid stainless steel shell, no seals.

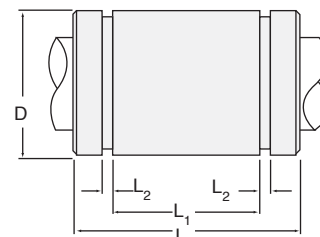
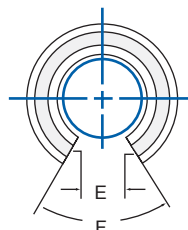

Nominal Shaft Dia.	LBB Bearing Part Number	D	L	L ₁	L ₂	E	F	Weight (lb.)	Normal Load (lb.)	Max Load (lb.)
3/8"	OPN375SS	0.6250/0.6246	.875	.562	.040	.25	60°	.04	35	50
1/2"	OPN-500SS	0.8750/0.8746	1.250	.875	.047	.28	60°	.10	71	101
5/8"	OPN-625SS	1.1250/1.1246	1.500	1.000	.058	.38	60°	.22	126	179
3/4"	OPN-750SS	1.2500/1.2496	1.625	1.062	.058	.40	60°	.25	143	203
1"	OPN-1000SS	1.5625/1.5621	2.250	1.625	.070	.56	60°	.49	270	385

INCH - INSTRUMENT SERIES CLOSED BEARINGS



- Designed for use on an end supported PowerTrax™ HG “ISL” shafting
- Solid stainless steel shell, no seals
- Require .0001" clearance
- Matched bearing and shaft assemblies are available

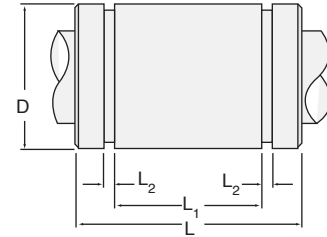

Nominal Shaft Dia.	LBB Bearing Part Number	D	L	L ₁	L ₂	Weight (lb.)	Normal Load (lb.)	Max Load (lb.)
1/8"	ILBB-125	.3125/.3121	.500	.312	.030	.02	7	9
3/16"	ILBB-187	.3750/.3746	.562	.375	.030	.04	9	11
1/4"	ILBB-250	.5000/.4996	.750	.437	.040	.11	17	25

LBB LINEAR BEARINGS TECHNICAL DATA

INCH - INSTRUMENT SERIES SHAFTING

For optimum performance, PowerTrax™ ILBB Instrument Bearings should be matched with PowerTrax™ HG “ISL” instrument shafting.

- Material:** 440C stainless steel
- Hardness:** Rc 55-60
- Diameter Tolerance:** .0001" for shafts thru 6" long
- Finish:** 2-4 microinch (rms)
- Straightness:** 0.001 per inch of length of the shaft.



INSTRUMENT SERIES LINEAR SHAFTING					
PART NUMBER	NOMINAL DIAMETER (inch)	TOLERANCES CLASS “I” DIAMETER (inches)	MAXIMUM LENGTH (inch)	MINIMUM DEPTH OF HARDNESS (inch)	WEIGHT PER INCH OF LENGTH (pounds)
ISL-125	1/8	.1248/.1247	12	.027	.004
ISL-187	3/16	.1873/.1872	12	.027	.008
ISL-250	1/4	.2498/.2497	12	.027	.014



LINEAR BEARING SEAL SPECIFICATIONS

PowerTrax™ Linear Bearing Seals are designed for use in custom housings where additional sealing is desired.

They are made of a synthetic rubber compound to allow smooth linear motion with maximum sealing efficiency.

LINEAR COMPONENTS TECHNICAL INTRODUCTION

PRECISION SERIES

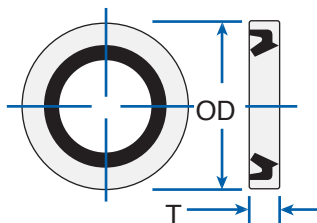

OPEN SERIES

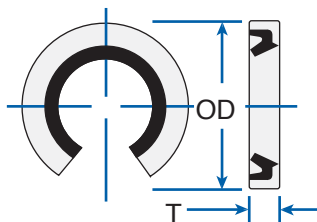

USE WITH POWERTRAX LINEAR BEARING	SHAFT DIAMETER INCH	PART NUMBER	DIMENSIONS	
			T	O.D.
PRECISION LINEAR BEARING SEALS				
LBB-250 LBB-375 LBB-500	1/4" 3/8" 1/2"	LS-250 LS-375 LS-500	0.125 0.125 0.125	0.504 0.629 0.879
LBB-625 LBB-750 LBB-1000	5/8" 3/4" 1"	LS-625 LS-750 LS-1000	0.125 0.125 0.187	1.129 1.254 1.567
LBB-1250 LBB-1500 LBB-2000	1-1/4" 1-1/2" 2"	LS-1250 LS-1500 LS-2000	0.375 0.375 0.375	2.004 2.379 3.004
STAINLESS STEEL LINEAR BEARING SEALS				
LBB-250SS LBB-375SS LBB-500SS	1/4" 3/8" 1/2"	LS-250SS LS-375SS LS-500SS	0.125 0.125 0.125	0.504 0.629 0.879
LBB-625SS LBB-750SS LBB-1000SS	5/8" 3/4" 1"	LS-625SS LS-750SS LS-1000SS	0.125 0.125 0.187	1.129 1.254 1.567

USE WITH POWERTRAX LINEAR BEARING	SHAFT DIAMETER INCH	PART NUMBER	DIMENSIONS	
			T	O.D.
OPEN LINEAR BEARING SEALS				
OPN-500 OPN-652	1/2" 5/8"	LSO-500 LSO-625	0.125 0.125	0.879 1.129
OPN-750 OPN-1000	3/4" 1"	LSO-750 LSO-1000	0.125 0.187	1.254 1.567
OPN-1250 OPN-1500	1-1/4" 1-1/2"	LSO-1250 LSO-1500	0.375 0.375	2.004 2.379
STAINLESS STEEL OPEN LINEAR BEARING SEALS				
OPN-375SS OPN-500SS OPN-625SS	3/8" 1/2" 5/8"	LSO-375SS LSO-500SS LSO-625SS	0.125 0.125 0.125	0.629 0.879 1.129
OPN-750SS OPN-1000SS	3/4" 1"	LSO-750SS LSO-1000SS	0.125 0.187	1.254 1.567

Prolong Bearing Assembly Reliability and Life.

Lubrication is the key to continued performance and reliability of bearing assemblies. LBL-1 is a multi-purpose pure synthetic lubricant. The stable and predictable chemical properties of LBL-1 help it

last longer and outperform conventional petroleum-based greases and oils. Lubricant additives fill microscopic surface irregularities to form a smooth, lubricated surface.



LBL-1 LUBRICANT FEATURES AND BENEFITS

- Synthetic, non-toxic, odorless
- Low coefficient of friction
- Free flowing at down to -40°
- USDA H-1 Rating
- Water and Saltwater Resistant
- Won't drip, run or evaporate
- Inhibits rust and corrosion
- Long lasting
- Reduces friction and wear

LBL-1 SPECIFICATIONS		
ISO GRADE	220	
PENETRATION (worked)	285	
DROPPING POINT	N/A	
GELLING AGENT	Synthetic	
TIMKEN OK LOAD	40 lbs.	
OIL VISCOSITY	cst @ 40°C	118-122
	cst @ 100°C	14-17
TEMPERATURE RANGE	-45° F TO 450° F	

LBL-1 4 oz. Liquid Bearing Bottle

LBL-1 LIQUID	
PART NAME	LBL-1
NET CONTENTS PER UNIT	4 oz.
PART # NLU-1006	1 BOTTLE weight of 4 oz.
PART # NLU-2006	1 CASE with 12 Bottles total weight of 3 lbs.



**POWERTRAX™ HG
GROUND & HARDENED SHAFTING**

Nook PowerTrax™ HG Shafting, made from high quality alloy steel, is manufactured and stocked for immediate shipment in our Cleveland, Ohio facility, in diameters from 5 to 80mm and 1/4 to 4 inches. Stainless Steel shafting is available from 1/4 thru 2 inch diameter.

Standard diameters can be cut to your specified length and shipped within 24 hours of receipt of your order. Contact Nook Industries, Inc. for availability of special diameters.

CASE HARDNESS

PowerTrax™ HG alloy shafting is induction hardened Rc 60-63. Stainless steel shafting is hardened to Rc 50-55. Instrument series shafting is hardened to Rc 55-60. The case depth on all PowerTrax™ HG Shafting is precisely controlled for optimal performance. The extremely hard surface minimizes wear and is resistant to nicks and scratches.



HARDENED AND PRECISION GROUND SHAFTING

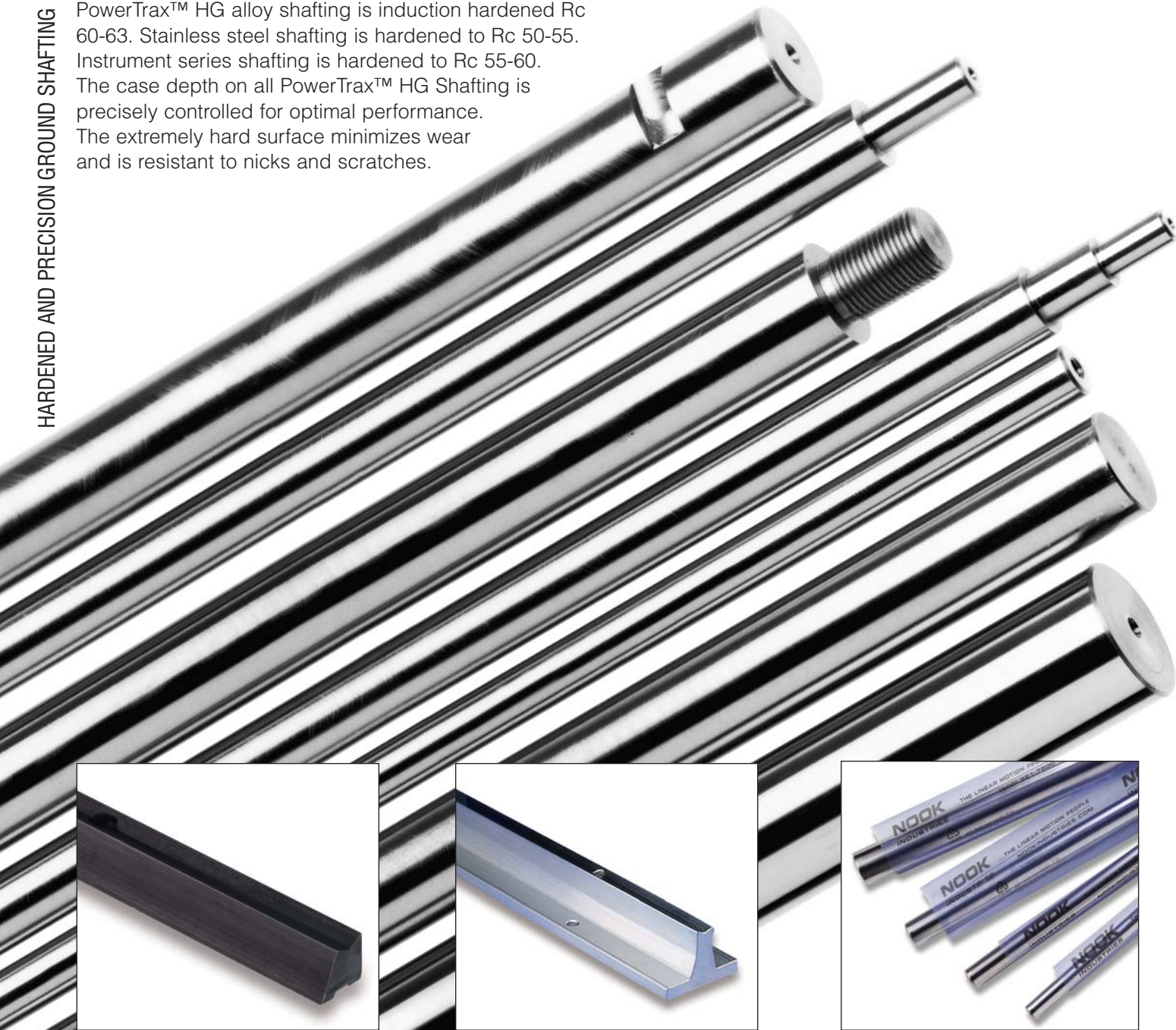



LINEAR SHAFTING					
PART NUMBER	NOMINAL DIAMETER (inches)	TOLERANCES CLASS "L" DIAMETER (inches)	MAXIMUM LENGTH (feet)	MINIMUM DEPTH OF HARDNESS (inches)	WEIGHT PER INCH OF LENGTH (pounds)
L-1/4*	1/4	.2495/.2490	10 (12)*	.030	.014
L-3/8*	3/8	.3745/.3740	10 (12)*	.030	.03
L-1/2*	1/2	.4995/.4990	18 (12)*	.050	.06
L-5/8*	5/8	.6245/.6240	18 (12)*	.050	.09
L-3/4*	3/4	.7495/.7490	18 (12)*	.060	.13
L-1*	1	.9995/.9990	18 (12)*	.080	.22
L-1-1/4	1-1/4	1.2495/1.2490	18 (12)*	.080	.35
L-1-1/2	1-1/2	1.4994/1.4989	18 (12)*	.080	.50
L-2	2	1.9994/1.9987	18 (12)*	.100	.89
L-2-1/2	2-1/2	2.4993/2.4985	18	.100	1.39
L-3	3	2.9992/2.9983	18	.100	2.00
L-4	4	3.9988/3.9976	18	.100	3.56

* Available in 440C stainless steel. For longer lengths contact Nook Industries.

PRE-DRILLED AND TAPPED LINEAR SHAFTING							
PART NUMBER	NOMINAL DIAMETER (inches)	TOLERANCES CLASS "L" DIAMETER (inches)	HOLE SPACING (inches)		THREAD SIZE	WEIGHT PER INCH OF LENGTH (pounds)	MAXIMUM LENGTH (feet)
			X	Y			
PDL 1/2*	1/2	.4995/.4990	4	2	6-32	.06	12
PDL 5/8*	5/8	.6245/.6240	4	2	8-32	.09	12
PDL 3/4*	3/4	.7495/.7490	6	3	10-32	.13	12
PDL 1*	1	.9995/.9990	6	3	1/4-20	.22	12
PDL 1-1/4	1-1/4	1.2495/1.2490	6	3	5/16-18	.35	12
PDL 1-1/2	1-1/2	1.4994/1.4989	8	4	3/8-16	.50	12
PDL 2	2	1.9994/1.9987	8	4	1/2-13	.89	12

Holes are drilled and tapped to center of shaft. For different hole spacing contact Nook Industries.

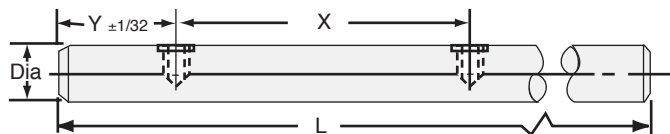

HARDENED AND PRECISION GROUND SHAFTING TECHNICAL DATA



Precut and Packaged Stock Length Shafting

- 1/2" to 1-1/2" diameters from 6" to 72" in length
- Precision center-less ground to 14 microinches rms surface finish or better
- 3 Materials to choose from:
 - Alloy Steel hardened to Rc 60
 - Stainless Steel hardened to Rc 50-55
 - Chrome-plated Alloy Steel
- Straightness: 0.001"/foot accumulative
- Cut length tolerance ±0.032"
- End cut perpendicularity ±0.032"
- Meets or exceeds specifications required by all other linear bearing manufacturers
- Packaged in VCI anti-corrosion protective sleeve
- Stocked for Immediate Availability
- Non-precision chamfered ends

HARDENED AND PRECISION GROUND SHAFTING TECHNICAL DATA

NS - 1 1/2 - L / SS / 18

DIAMETER

Available Diameters

Part#	Dia.	Part#	Dia.	Part#	Dia.
1/4-L	= 1/4"	5/8-L	= 5/8"	1 1/4-L	= 1 1/4"
3/8-L	= 3/8"	3/4-L	= 3/4"	1 1/2-L	= 1 1/2"
1/2-L	= 1/2"	1-L	= 1"		

MATERIAL

HC = High Carbon Alloy Steel Heat Treated to Rc 60
 SS = Stainless Steel - 440C
 CP = Chrome Plated Alloy

OVERALL LENGTH

OAL tolerances will be ± 0.010"

Part #	Length	Part #	Length	Part #	Length
6	= 6"	24	= 24"	48	= 48"
12	= 12"	30	= 30"	60	= 60"
18	= 18"	36	= 36"	72	= 72"

NOOK SHAFT PRECUT STOCKED LINEAR SHAFTING				
NOMINAL DIAMETER (inches)	STOCK LENGTHS (inches)	TOLERANCES CLASS "L" DIAMETER (inches)	MINIMUM DEPTH OF HARDNESS (inches)	WEIGHT PER INCH OF LENGTH (pounds)
1/4	6, 12, 18, 24, 30, 36, 48, 60	.2495/.2490	.030	.014
3/8	6, 12, 18, 24, 36, 48, 60	.3745/.3740	.030	.031
1/2	12, 18, 24, 30, 36, 42, 48, 60	.4995/.4990	.050	.055
5/8	12, 18, 24, 30, 36, 42, 48, 54, 60	.6245/.6240	.050	.086
3/4	12, 18, 24, 30, 36, 42, 48, 54, 60	.7495/.7490	.060	.125
1	18, 24, 30, 36, 42, 48, 54, 60, 72	.9995/.9990	.080	.222
1-1/4	18, 24, 30, 36, 42, 48, 54, 60, 72	1.2495/1.2490	.080	.348
1-1/2	18, 24, 36, 48, 54, 60, 72	1.4994/1.4989	.080	.500



PRECISION END MACHINING

PowerTrax™ HG hardened and ground shafting is manufactured for use with precision linear bearings and other applications requiring an accurate, round, hardened shaft or guide rod. All linear shafting can be

machined by Nook Industries, Inc. to any of the configurations detailed below. Templates for machining are available on our website—www.nookindustries.com

RADIAL HOLES DRILLED AND TAPPED

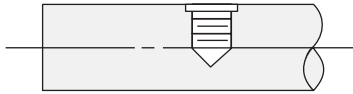

Radial drilled and tapped holes are available with either UNC or UNF Class 2B thread. The hole alignment and location tolerance is $\pm .010$ ".

COAXIAL HOLES

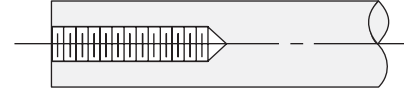

Coaxial holes are machined with concentricity of $.005$ " centered in the shaft end for shafting 1/2 inch diameter and larger. UNC or UNF Class 2B internal threads are available. Based on tapped hole size, some ends may require annealing and will remain soft on the outside diameter.

RETAINING RING GROOVES



Retaining ring or other grooves area available for all diameter shafting. Annealing may require be in the machined area.

OPTIONAL MACHINED CHAMFER

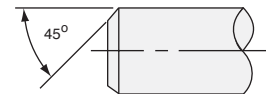

Cut shafts are supplied with Nook non-precision standard end chamfers. Specific chamfer dimensions may be specified.

THREADED DIAMETERS

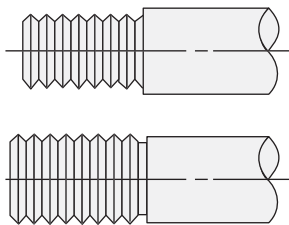

Either the major diameter or reduced diameter may be threaded to UNC or UNF Class 2A. Threaded areas will not have full depth of hardness.

REDUCED DIAMETER

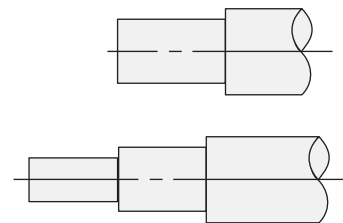

Single or multiple-step machined diameters are available. Concentricity held within $.002$ ". The reduced diameters will not have full hardness.

FLATS – SINGLE OR MULTIPLE

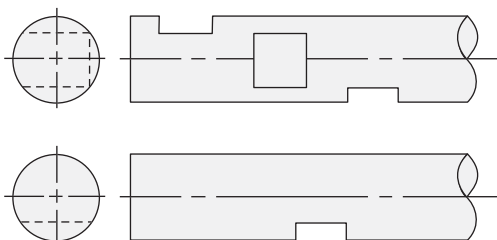

Flats have a location tolerance of $\pm 1/64$ ". Multiple flats available on single plane or different planes with location tolerance $\pm 1/64$ ". Contact Nook Industries, Inc. for flat length limits.

KEYWAYS

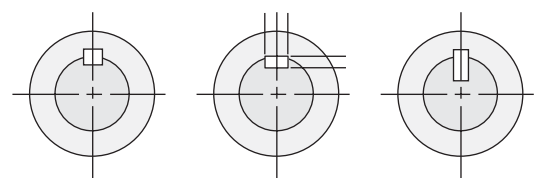

Keyways are available for square, rectangular or ANSI Standard Woodruff keys. Keyway diameter will not have full hardness.

HARDENED AND PRECISION GROUND SHAFTING TECHNICAL DATA



LOW-PROFILE: SHAFT SUPPORT RAILS

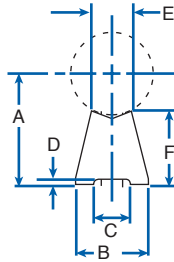

STANDARD LENGTHS:
12", 24", 36", and 48"

HOW TO ORDER:
State appropriate part number and length.
NLR-10-xx xx=OAL [inches]

MATERIAL: Aluminum alloy extrusion

PART NO.	NOM. SHAFT DIA. (in.)	A ±.002	B	C	D	E	F	WT. PER FT./LBS.
NLR-8	1/2	.5625	.370	.169	.04	.226	.338	.11
NLR-10	5/8	.6875	.450	.193	.04	.278	.406	.17
NLR-12	3/4	.7500	.510	.221	.06	.335	.412	.21
NLR-16	1	1.000	.690	.281	.06	.456	.551	.36
NLR-20	1-1/4	1.1875	.780	.343	.09	.518	.617	.45
NLR-24	1-1/2	1.3750	.930	.406	.09	.635	.693	.60

SHAFTING SUPPORTS TECHNICAL DATA

LOW PROFILE: PREDRILLED SHAFT SUPPORT RAILS

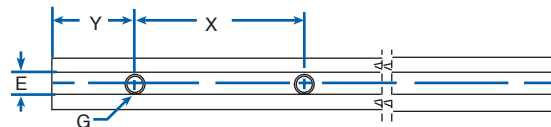
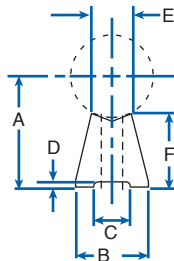

STANDARD LENGTHS: 12", 24", 36" and 48"

HOW TO ORDER:
State appropriate part number and length.
NLR-8-PD-xx xx=OAL [inches]

MATERIAL: Aluminum alloy extrusion

PART NO.	NOM. SHAFT DIA. (in.)	A ±.002	B	C	D	E	F	G		Y	X	WT. PER FT./LBS.
								BOLT	HOLE			
NLR-8-PD	1/2	.5625	.370	.169	.04	.226	.338	6	.169	2	4	.11
NLR-10-PD	5/8	.6875	.450	.193	.04	.278	.406	8	.193	2	4	.17
NLR-12-PD	3/4	.7500	.510	.221	.06	.335	.412	10	.221	3	6	.21
NLR-16-PD	1	1.000	.690	.281	.06	.456	.551	1/4	.281	3	6	.36
NLR-20-PD	1-1/4	1.1875	.780	.343	.09	.518	.617	5/16	.343	3	6	.45
NLR-24-PD	1-1/2	1.3750	.930	.406	.09	.635	.693	3/8	.406	4*	8	.60

*2 on 36" length

SHAFT SUPPORT RAILS

SHAFT SUPPORT RAILS

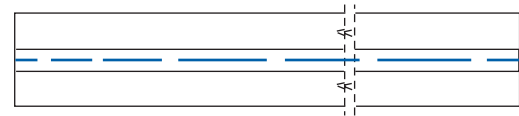
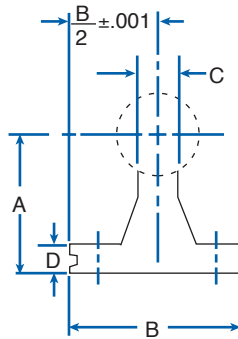

STANDARD LENGTHS: 24", 36", and 48"
Special lengths available, contact the factory.

HOW TO ORDER:

State appropriate part number and length.
NSR-10-xx xx=OAL [inches]

MATERIAL: Aluminum alloy extrusion

PART NO.	NOM. SHAFT DIA. (in.)	A ±.002	B	C	D	WT. PER FT./LBS.
NSR-8	1/2	1.125	1-1/2"	1/4"	3/16"	.6
NSR-10	5/8	1.125	1-5/8"	5/16"	1/4"	.8
NSR-12	3/4	1.500	1-3/4"	3/8"	1/4"	1.0
NSR-16	1	1.750	2-1/8"	1/2"	1/4"	1.4
NSR-20	1-1/4	2.125	2-1/2"	9/16"	5/16"	2.1
NSR-24	1-1/2	2.500	3"	11/16"	3/8"	2.6
NSR-32	2	3.250	3-3/4"	7/8"	1/2"	4.2

PREDRILLED SHAFT SUPPORT RAILS

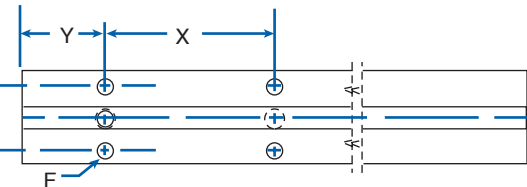
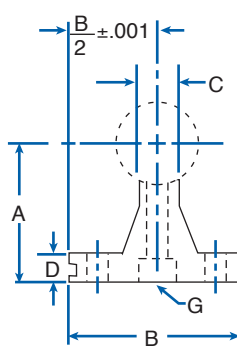

STANDARD LENGTHS: 24", 36", and 48"

HOW TO ORDER:

State appropriate part number and length.
NSR-8-PD-xx xx=OAL [inches]

MATERIAL: Aluminum alloy extrusion

PART NO.	NOM. SHAFT DIA. (in.)	A ±.002	B	C	D	E	F		G		Y	X	WT. PER FT./LBS.
							BOLT	HOLE	SCREW	HOLE			
NSR-8-PD	1/2	1.125	1-1/2"	1/4"	3/16"	1"	6	.169	6-32 x 7/8	.169"	2	4	.5
NSR-10-PD	5/8	1.125	1-5/8"	5/16"	1/4"	1-1/8"	8	.193	8-32 x 7/8	.193"	2	4	.7
NSR-12-PD	3/4	1.500	1-3/4"	3/8"	1/4"	1-1/4"	10	.221	10-32 x 7/8	.221"	3	6	.9
NSR-16-PD	1	1.750	2-1/8"	1/2"	1/4"	1-1/2"	1/4"	.281	1/4-20 x 1-1/2	.281"	3	6	1.2
NSR-20-PD	1-1/4	2.125	2-1/2"	9/16"	5/16"	1-7/8"	5/16"	.343	5/16-18 x 1-3/4	.343"	3	6	2.0
NSR-24-PD	1-1/2	2.500	3"	11/16"	3/8"	2-1/4"	3/8"	.406	3/8-16 x 2	.406"	4*	8	2.4
NSR-32-PD	2	3.250	3-3/4"	7/8"	1/2"	2-3/4"	1/2"	.531	1/2-13 x 2-1/2	.531"	4*	8	4.0

*2 on 36" length

The specifications and data in this publication are believed to be accurate and reliable. However, it is the responsibility of the product user to determine the suitability of Nook Industries products for a specific application. While defective products will be replaced without charge if promptly returned, no liability is assumed beyond such replacement.



PREDRILLED SHAFT SUPPORT ASSEMBLIES

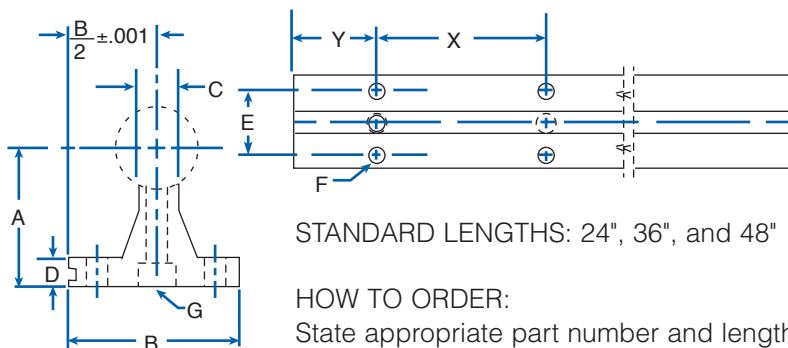

STANDARD LENGTHS: 24", 36", and 48"

HOW TO ORDER:
State appropriate part number and length.
NSR-32-PDA-xx xx=OAL [inches]

SHAFTING SUPPORTS TECHNICAL DATA

PART NO.	NOM. SHAFT DIA. (in.)	A ±.002	B	C	D	E	F		G		Y	X	WT. PER FT./LBS.
							BOLT	HOLE	SCREW	HOLE			
NSR-8-PDA	1/2	1.125	1-1/2"	1/4"	3/16"	1"	6	.169	6-32 x 7/8	.169	2	4	1.26
NSR-10-PDA	5/8	1.125	1-5/8"	5/16"	1/4"	1-1/8"	8	.193	8-32 x 7/8	.193	2	4	1.83
NSR-12-PDA	3/4	1.500	1-3/4"	3/8"	1/4"	1-1/4"	10	.221	10-32 x 1-1/4	.221	3	6	2.50
NSR-16-PDA	1	1.750	2-1/8"	1/2"	1/4"	1-1/2"	1/4"	.281	1/4-20 x 1-1/2	.281	3	6	4.06
NSR-20-PDA	1-1/4	2.125	2-1/2"	9/16"	5/16"	1-7/8"	5/16"	.343	5/16-18 x 1-3/4	.343	3	6	6.28
NSR-24-PDA	1-1/2	2.500	3"	11/16"	3/8"	2-1/4"	3/8"	.406	3/8-16 x 2	.406	4*	8	8.60
NSR-32-PDA	2	3.250	3-3/4"	7/8"	1/2"	2-3/4"	1/2"	.531	1/2-13 x 2-1/2	.531	4*	8	14.88

*2 on 36" length

SHAFT SUPPORT BLOCKS

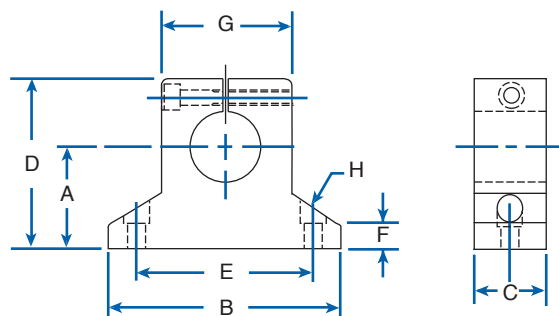

PART NO.	NOM. SHAFT DIA. (in.)	A ±.001	B	C	D	E ± 0.010	F	G	H		WEIGHT EACH
									BOLT	HOLE	
NSB-4	1/4	.687	1-1/2"	1/2"	1-1/16"	1-1/8"	1/4"	.63	#6	5/32"	.03
NSB-6	3/8	.750	1-5/8"	9/16"	1-3/16"	1-1/4"	1/4"	.75	#6	5/32"	.05
NSB-8	1/2	1.000	2"	5/8"	1-5/8"	1-1/2"	1/4"	.88	#8	3/16"	.14
NSB-10	5/8	1.000	2-1/2"	11/16"	1-3/4"	1-7/8"	5/16"	1.13	#10	7/32"	.16
NSB-12	3/4	1.250	2-3/4"	3/4"	2-1/8"	2"	5/16"	1.25	#10	7/32"	.21
NSB-16	1	1.500	3-1/4"	1"	2-9/16"	2-1/2"	3/8"	1.50	1/4"	9/32"	.40
NSB-20	1-1/4	1.750	4"	1-1/8"	3"	3"	7/16"	2.00	5/16"	11/32"	.80
NSB-24	1-1/2	2.000	4-3/4"	1-1/4"	3-1/2"	3-1/2"	1/2"	2.25	5/16"	11/32"	1.10
NSB-32	2	2.500	6"	1-1/2"	4-3/8"	4-1/2"	5/8"	3.00	3/8"	13/32"	1.90

A PowerTrax™ Series slide assembly is truly a “System” not just a “Component”. The matched components used in PowerTrax™ Slides result in better system performance. When PowerTrax™ Slide Systems are used as sub-assemblies set-up and alignment time is reduced. PowerTrax™ Slide Systems are easier to specify and to order.

POWERTRAX™ SLIDE SYSTEM FEATURES

Precision carriage plates supplied with Series 130, 200 and MM Slide™, help prevent misaligned shafts and bearings.

Aluminum carriage plates include threaded steel inserts at key mounting locations.

Protective, non-corrosive finish on all exposed non-wear components.

PowerTrax™ Slide Systems have been engineered by Nook Industries for use in the following applications:

- Product Packaging
- Electronics Manufacturing
- Food Processing
- Machine Tool Equipment
- Component Assembly
- Material Handling
- Converting Processes
- Container Manufacturing
- Medical Equipment
- Textile Industry
- Automated Test Equipment

Contact Nook Industries, Inc. to discuss special requirements. Modifications include:

- Special screws (ground thread, precision rolled with preloaded nuts, high lead screws, metric lead screws, etc.)
- Protective boots in a variety of materials (neoprene, metallic, etc.)
- Special motor mounts (Servos, steppers, etc.)
- Custom carriage machining

SERIES 100 SLIDE SYSTEMS



PowerTrax™ Series 100 slide systems are pre-assembled and ready to mount. Series 100 slides consist of combinations of PowerTrax™ Linear Ball Bearing Pillow Blocks, HG shafting, carriage plates and shaft supports. Aluminum carriage plates include threaded steel inserts at key mounting locations. All exposed non-wearing components have a protective, corrosion resistant finish.



SERIES 200 SLIDE SYSTEMS

PowerTrax™ Series 200 slide systems are assembled slides which include:

- Linear Bearing pillow blocks
- Integrated end supports
- HG linear shafts
- Carriage plate
- PowerAc™ or PowerTrac™ Screw assembly

Many options are available for these slide systems. Different screw styles and leads, protective boots, special motor mounts and custom carriage plate machining is available. Contact Nook Industries, Inc. for assistance.

MM SLIDE™ MINI SLIDE SYSTEMS

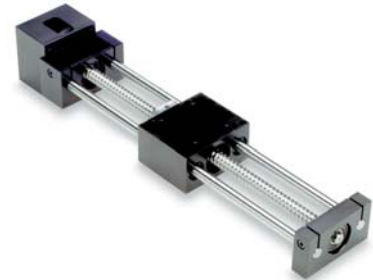

PowerTrax™ MM Slide™ are metric-dimensioned compact slide units. They utilize lightweight aluminum components and include an integrated carriage/pillow block assembly for a reduced overall height. A wide variety of screw diameters, leads and nut styles are available. These systems include:

- EXCEL™ linear bearings
- Integrated end supports
- HG linear shafts
- Carriage/pillow block assembly
- Lead screw assembly



212 - 12 - L 24 / 0750-0200 SRT / A34 / S

MODEL

MM SLIDE™

012 = Double Shaft End Supported System with Screw

SERIES 200

211 = Double Shaft End Supported System without Screw

251 = Double Shaft Fully Supported System without Screw

212 = Double Shaft End Supported System with Screw

252 = Double Shaft Fully Supported System with Screw

SERIES 300

302 = Double Shaft End Supported System without Screw

312 = Double Shaft Fully Supported System with Screw

SHAFT DIAMETER

Diameter of the shaft in sixteenth of an inch

MM SLIDE™

6 = 3/8 Inch

SERIES 200

8 = 1/2 Inch

12 = 3/4 inch

16 = 1 inch

24 = 1 1/2 inch

SERIES 300

8 = 1/2 Inch

12 = 3/4 inch

16 = 1 inch

OVERALL LENGTH

OAL Including end blocks, are inches preceded by an "L".

NOTE:

See description on the following pages for actual travel distance and standard lengths.

SCREW SPECIFICATION

Screw Size is matched to the diameter of the shaft. Select either an Acme or Ball Screw Part Number.

MM SLIDE™		
SHAFT Dia.	SPEEDY™ Screw Part #	CARRY™ Screw Part #
6 (3/8")	11 x 60	12 x 4 12 x 5
	13 x 70	
	14 x 8	
	14 x 18	
	14 x 30	

SERIES 200		
SHAFT Dia.	ACME SCREW Part #	BALL SCREW Part #
8 (1/2")	1/2-1	0500-0200 SRT 0500-0500 SRT
	1/2-2	
	1/2-5	
	1/2-10	
12 (3/4")	3/4-10	0750-0200 SRT 0750-0500 SRT
16 (1")	1-1	1000-0250 SRT
	1-10	1000-0500 SRT 1000-1000 SRT
24 (1-1/2")	1-1/2-2	1500-0250 SRT
	1-1/2-2-2/3	1500-0500 SRT
	1-1/2-4	1500-1000 SRT
	1-1/2-5	1500-1875 SRT
	1-1/2-10	1500-0500 XPR

SERIES 300		
SHAFT Dia.	ACME SCREW Part #	BALL SCREW Part #
8 (1/2")	3/8-2	0375-0125 SRT
	3/8-4	
	3/8-5	
	3/8-6	
	3/8-8	
	3/8-10	
	3/8-12	
12 (3/4")	3/8-16	0500-0200 SRT 0500-0500 SRT
	1/2-1	
	1/2-2	
	1/2-4	
16 (1")	1/2-5	0750-0200 SRT 0750-0500 SRT
	1/2-10	
	3/4-10	

MOTOR ADAPTERS

MM SLIDE™

A23 = 23 Frame for the **6** (3/8")

00 = No motor adapter

SERIES 200

A23 = 23 Frame for the **8** (1/2") and **12** (3/4") Slide

A34 = 34 Frame size for **16** (1") Slide

A42 = 42 Frame size for **24** (1 1/2") Slide

00 = No motor adapter

SERIES 300

A23 = 23 Frame for the **8** (1/2") and **12** (3/4") Slide

A34 = 34 Frame size for **16** (1") Slide

00 = No motor adapter

MODIFIER LIST

ALWAYS S or M

S = Standard, no additional description or modification required

M = Modified, additional description required

B = Boot, the "L" dimension must be increased by .1" times travel in order to accommodate the retracted boot

CARRIAGE MOUNTING PLATES

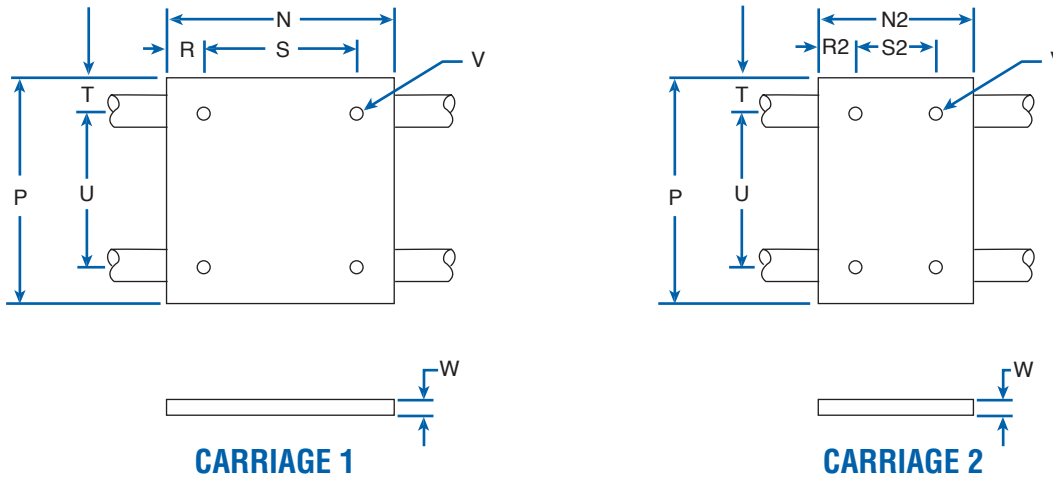

CARRIAGE MOUNTING PLATES

NOMINAL SHAFT DIA.	DIMENSION (inches)										
	CARRIAGE 1			COMMON TO CARRIAGE 1 & 2					CARRIAGE 2		
	N	R	S	P	T	U	V	W	N2	R2	S2
1/2	5.50	.500	4.50	5.50	1.125	3.25	1/4-20	.375	3.50	.50	2.50
3/4	7.50	.750	6.00	7.50	1.500	4.50	5/16-18	.50	4.50	.75	3.00
1	9.00	1.000	7.00	9.00	1.750	5.50	3/8-16	.50	6.00	1.00	4.00
1-1/2	13.00	1.500	10.00	13.00	2.500	8.00	1/2-13	.75	9.00	1.50	6.00

Material: Aluminum Alloy Black Anodized

SERIES 111: SINGLE SHAFT UNSUPPORTED SYSTEM

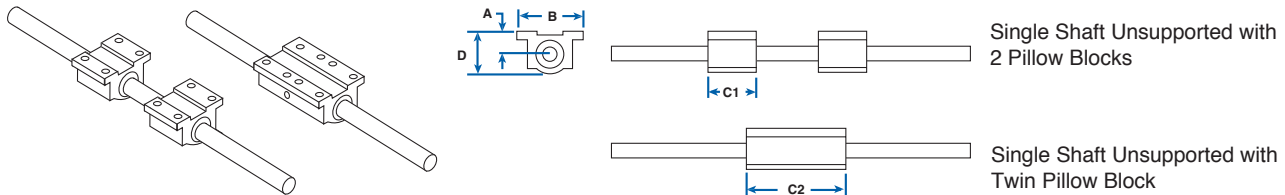

SINGLE SHAFT UNSUPPORT WITH 2 PILLOW BLOCKS

PART NO.	NOM. SHAFT DIA. (in.)	LOAD (lbf)* MAX/BLOCK	DIMENSION (inches)				PILLOW BLOCK**
			A ±.001	B	C1	D	
111-06-SXX	3/8	68	0.500	1.75	1.31	0.94	XEP-6
111-08-SXX	1/2	175	0.687	2.00	1.69	1.25	XEP-8
111-12-SXX	3/4	406	0.937	2.75	2.06	1.75	XEP-12
111-16-SXX	1	725	1.187	3.25	2.81	2.19	XEP-16
111-24-SXX	1-1/2	1,376	1.750	4.75	4.00	3.25	XEP-24

SINGLE SHAFT UNSUPPORTED WITH TWIN PILLOW BLOCKS

PART NO.	NOM. SHAFT DIA. (in.)	LOAD (lbf)* MAX/BLOCK	DIMENSION (inches)				PILLOW BLOCK**
			A ±.001	B	C2	D	
111-06-TXX	3/8	136	0.500	1.75	2.75	0.94	TEP-6
111-08-TXX	1/2	350	0.687	2.00	3.50	1.25	TEP-8
111-12-TXX	3/4	812	0.937	2.75	4.50	1.75	TEP-12
111-16-TXX	1	1,450	1.187	3.25	6.00	2.19	TEP-16
111-24-TXX	1-1/2	2,752	1.750	4.75	9.00	3.25	TEP-24

* Based on horizontal load, equally distributed to each bearing with a travel life of 2 million inches. ** See pages 231-232 for details. XX = shaft length - see page 241.

The specifications and data in this publication are believed to be accurate and reliable. However, it is the responsibility of the product user to determine the suitability of Nook Industries products for a specific application. While defective products will be replaced without charge if promptly returned, no liability is assumed beyond such replacement.



SERIES 121: SINGLE SHAFT END SUPPORTED SYSTEM

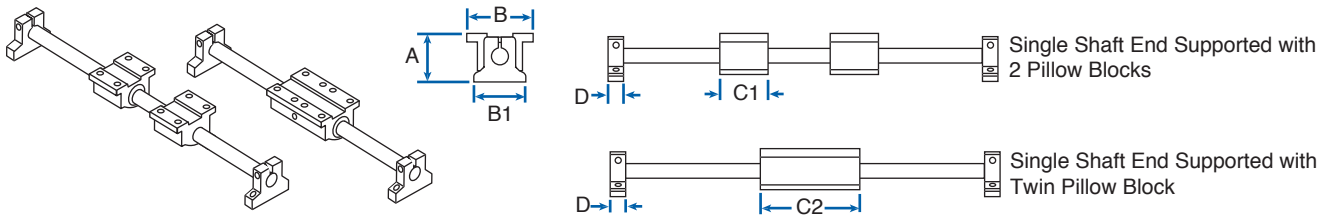

SINGLE SHAFT END SUPPORTED WITH 2 PILLOW BLOCKS

PART NO.	NOM. SHAFT DIA. (in.)	LOAD (lbf)* MAX/BLOCK	DIMENSION (inches)					PILLOW BLOCK**	END SUPPORT*
			A ±.003	B	B1	C1	D		
121-06-SXX	3/8	68	1.250	1.75	1.63	1.31	0.56	XEP-6	NSB-6
121-08-SXX	1/2	175	1.687	2.00	2.00	1.69	0.63	XEP-8	NSB-8
121-12-SXX	3/4	406	2.187	2.75	2.75	2.06	0.75	XEP-12	NSB-12
121-16-SXX	1	725	2.687	3.25	3.25	2.81	1.00	XEP-16	NSB-16
121-24-SXX	1-1/2	1,376	3.750	4.75	4.75	4.00	1.25	XEP-24	NSB-24

SINGLE SHAFT END SUPPORTED WITH TWIN PILLOW BLOCK

PART NO.	NOM. SHAFT DIA. (in.)	LOAD (lbf)* MAX/BLOCK	DIMENSION (inches)					MAX. STROKE LENGTH (in.)	PILLOW BLOCK**	END SUPPORT*
			A ±.003	B	B1	C2	D			
121-06-TXX	3/8	136	1.250	1.75	1.63	2.75	0.56	L-(3.88)	TEP-6	NSB-6
121-08-TXX	1/2	350	1.687	2.00	2.00	3.50	0.63	L-(4.75)	TEP-8	NSB-8
121-12-TXX	3/4	812	2.187	2.75	2.75	4.50	0.75	L-(6.00)	TEP-12	NSB-12
121-16-TXX	1	1,450	2.687	3.25	3.25	6.00	1.00	L-(8.00)	TEP-16	NSB-16
121-24-TXX	1-1/2	2,752	3.750	4.75	4.75	9.00	1.25	L-(11.50)	TEP-24	NSB-24

* Based on horizontal load, equally distributed to each bearing with a travel life of 2 million inches. ** See pages 231-232 for details. XX = shaft length - see page 241.

SERIES 131: SINGLE SHAFT FULLY SUPPORTED SYSTEM

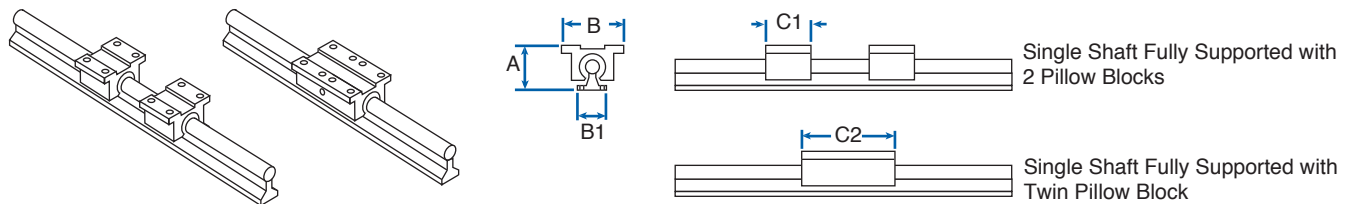

SINGLE SHAFT FULLY SUPPORTED WITH 2 PILLOW BLOCKS

PART NO.	NOM. SHAFT DIA. (in.)	LOAD (lbf)* MAX/BLOCK	DIMENSION (inches)				PILLOW BLOCK**
			A ±.003	B	C1	B1	
131-08-SXX	1/2	152	1.812	2.00	1.69	1.50	XEP-08-OPN
131-12-SXX	3/4	398	2.437	2.75	2.06	1.75	XEP-12-OPN
131-16-SXX	1	711	2.937	3.25	2.81	2.13	XEP-16-OPN
131-24-SXX	1-1/2	1,346	4.250	4.75	4.00	3.00	XEP-24-OPN

SINGLE SHAFT FULLY SUPPORTED WITH TWIN PILLOW BLOCK

PART NO.	NOM. SHAFT DIA. (in.)	LOAD (lbf)* MAX/BLOCK	DIMENSION (inches)				PILLOW BLOCK**
			A ±.003	B	C2	B1	
131-08-TXX	1/2	304	1.812	2.00	3.50	1.50	TEP-08-OPN
131-12-TXX	3/4	796	2.437	2.75	4.50	1.75	TEP-12-OPN
131-16-TXX	1	1,422	2.937	3.25	6.00	2.13	TEP-16-OPN
131-24-TXX	1-1/2	2,692	4.250	4.75	9.00	3.00	TEP-24-OPN

* Based on horizontal load, equally distributed to each bearing with a travel life of 2 million inches. ** See pages 231-232 for details. XX = shaft length - see page 241.

PRECISION LINEAR SLIDE SYSTEMS TECHNICAL DATA

SERIES 112 AND 122 SLIDE SYSTEMS

SERIES 112: DOUBLE SHAFT UNSUPPORTED SYSTEM

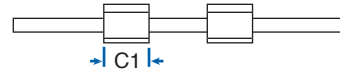
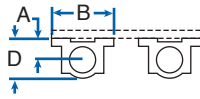
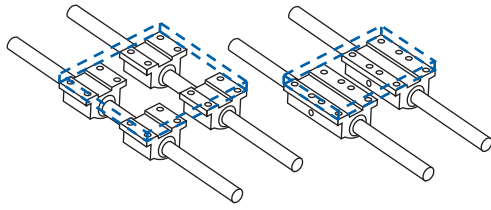

Double Shaft Unsupported with 4 Pillow Blocks

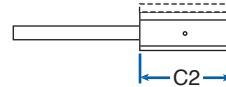

Double Shaft Unsupported with 2 Twin Pillow Blocks

DOUBLE SHAFT UNSUPPORTED WITH 4 PILLOW BLOCKS

PART NO.	NOM. SHAFT DIA. (in.)	LOAD (lbf)*		DIMENSION (inches)				PILLOW BLOCK**
		MAX/SYSTEM	MAX/BLOCK	A ±.001	B	C1	D	
112-06-SXX	3/8	272	68	0.500	1.75	1.31	0.94	XEP-6
112-08-SXX	1/2	700	175	0.687	2.00	1.69	1.25	XEP-8
112-12-SXX	3/4	1,624	406	0.937	2.75	2.06	1.75	XEP-12
112-16-SXX	1	2,900	725	1.187	3.25	2.81	2.19	XEP-16
112-24-SXX	1-1/2	5,504	1,376	1.750	4.75	4.00	3.25	XEP-24

DOUBLE SHAFT UNSUPPORTED WITH 2 TWIN PILLOW BLOCKS

PART NO.	NOM. SHAFT DIA. (in.)	LOAD (lbf)*		DIMENSION (inches)				PILLOW BLOCK**
		MAX/SYSTEM	MAX/BLOCK	A ±.001	B	C2	D	
112-06-TXX	3/8	272	136	0.500	1.75	2.75	0.94	TEP-6
112-08-TXX	1/2	700	350	0.687	2.00	3.50	1.25	TEP-8
112-12-TXX	3/4	1,624	812	0.937	2.75	4.50	1.75	TEP-12
112-16-TXX	1	2,900	1,450	1.187	3.25	6.00	2.19	TEP-16
112-24-TXX	1-1/2	5,504	2,752	1.750	4.75	9.00	3.25	TEP-24

* Based on horizontal load, equally distributed to each bearing with a travel life of 2 million inches. ** See pages 231-232 for details. XX = shaft length - see page 241.

SERIES 122: DOUBLE SHAFT END SUPPORTED SYSTEM

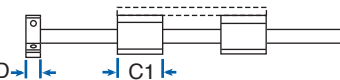
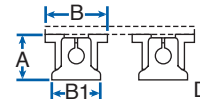
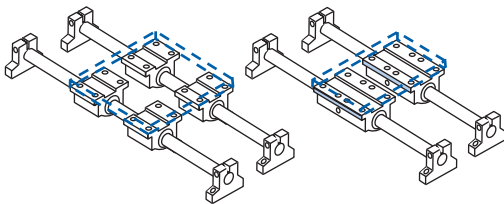

Double Shaft End Supported with 4 Pillow Blocks

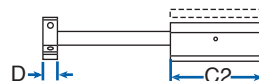

Double Shaft End Supported with 2 Twin Pillow Blocks

DOUBLE SHAFT END SUPPORTED WITH 4 PILLOW BLOCKS

PART NO.	NOM. SHAFT DIA. (in.)	LOAD (lbf)*		DIMENSION (inches)					PILLOW BLOCK**	END SUPPORT*
		MAX/SYSTEM	MAX/BLOCK	A ±.003	B	B1	C1	D		
122-06-SXX	3/8	272	68	1.250	1.75	1.63	1.31	0.56	XEP-6	NSB-6
122-08-SXX	1/2	700	175	1.687	2.00	2.00	1.69	0.63	XEP-8	NSB-8
122-12-SXX	3/4	1,624	406	2.187	2.75	2.75	2.06	0.75	XEP-12	NSB-12
122-16-SXX	1	2,900	725	2.687	3.25	3.25	2.81	1.00	XEP-16	NSB-16
122-24-SXX	1-1/2	5,504	1,376	3.750	4.75	4.75	4.00	1.25	XEP-24	NSB-24

DOUBLE SHAFT END SUPPORTED WITH 2 TWIN PILLOW BLOCKS

PART NO.	NOM. SHAFT DIA. (in.)	LOAD (lbf)*		DIMENSION (inches)					MAX. STROKE LENGTH (in.)	PILLOW BLOCK**	END SUPPORT*
		MAX/SYSTEM	MAX/BLOCK	A ±.003	B	B1	C2	D			
122-06-TXX	3/8	272	136	1.250	1.75	1.63	2.75	0.56	L-(3.88)	TEP-6	NSB-6
122-08-TXX	1/2	700	350	1.687	2.00	2.00	3.50	0.63	L-(4.75)	TEP-8	NSB-8
122-12-TXX	3/4	1,624	812	2.187	2.75	2.75	4.50	0.75	L-(6.00)	TEP-12	NSB-12
122-16-TXX	1	2,900	1,450	2.687	3.25	3.25	6.00	1.00	L-(8.00)	TEP-16	NSB-16
122-24-TXX	1-1/2	5,504	2,752	3.750	4.75	4.75	9.00	1.25	L-(11.50)	TEP-24	NSB-24

* Based on horizontal load, equally distributed to each bearing with a travel life of 2 million inches. ** See pages 231-232 for details. XX = shaft length - see page 241.

The specifications and data in this publication are believed to be accurate and reliable. However, it is the responsibility of the product user to determine the suitability of Nook Industries products for a specific application. While defective products will be replaced without charge if promptly returned, no liability is assumed beyond such replacement.



SERIES 132: DOUBLE SHAFT FULLY SUPPORTED SYSTEM

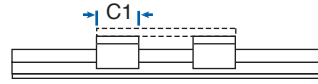
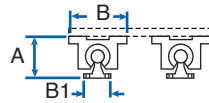
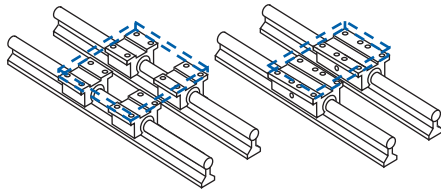

Double Shaft Fully Supported with 4 Pillow Blocks

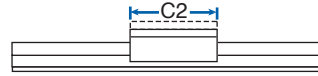

Double Shaft Fully Supported with 2 Twin Pillow Blocks

DOUBLE SHAFT FULLY SUPPORTED WITH 4 PILLOW BLOCKS

PART NO.	NOM. SHAFT DIA. (in.)	LOAD (lbf)*		DIMENSION (inches)				PILLOW BLOCK**
		MAX/SYSTEM	MAX/BLOCK	A ±.003	B	B1	C1	
132-08-SXX	1/2	608	152	1.812	2.00	1.50	1.69	XEP-8-OPN
132-12-SXX	3/4	1,584	398	2.437	2.75	1.75	2.06	XEP-12-OPN
132-16-SXX	1	2,844	711	2.937	3.25	2.13	2.81	XEP-16-OPN
132-24-SXX	1-1/2	5,384	1,346	4.250	4.75	3.00	4.00	XEP-24-OPN

DOUBLE SHAFT FULLY SUPPORTED WITH 2 TWIN PILLOW BLOCKS

PART NO.	NOM. SHAFT DIA. (in.)	LOAD (lbf)*		DIMENSION (inches)				PILLOW BLOCK**
		MAX/SYSTEM	MAX/BLOCK	A ±.003	B	B1	C2	
132-08-TXX	1/2	608	304	1.812	2.00	1.50	3.50	TEP-8-OPN
132-12-TXX	3/4	1,584	796	2.437	2.75	1.75	4.50	TEP-12-OPN
132-16-TXX	1	2,844	1,422	2.937	3.25	2.13	6.00	TEP-16-OPN
132-24-TXX	1-1/2	5,384	2,692	4.250	4.75	3.00	9.00	TEP-24-OPN

* Based on horizontal load, equally distributed to each bearing with a travel life of 2 million inches. ** See pages 231-232 for details. XX = shaft length - see page 241.

SERIES 113: DOUBLE SHAFT UNSUPPORTED SYSTEM WITH CARRIAGE

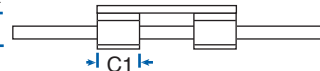
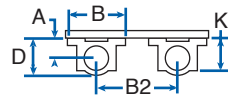
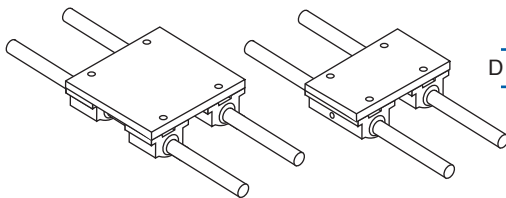

Double Shaft Unsupported with 4 Pillow Blocks and Carriage 1

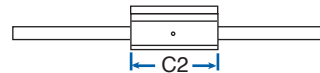

Double Shaft Unsupported with 2 Twin Pillow Blocks and Carriage 2

DOUBLE SHAFT UNSUPPORTED WITH 4 PILLOW BLOCKS AND CARRIAGE 1

PART NO.	NOM. SHAFT DIA. (in.)	LOAD (lbf)* MAX/SYSTEM	DIMENSION (inches)					PILLOW BLOCK**
			A ±.001	B	B2	C1	D	
113-08-SXX	1/2	700	0.687	2.00	3.25	1.69	1.25	XEP-8
113-12-SXX	3/4	1,624	0.937	2.75	4.50	2.06	1.75	XEP-12
113-16-SXX	1	2,900	1.187	3.25	5.50	2.81	2.19	XEP-16
113-24-SXX	1-1/2	5,504	1.750	4.75	8.00	4.00	3.25	XEP-24

DOUBLE SHAFT UNSUPPORTED WITH 2 TWIN PILLOW BLOCKS AND CARRIAGE 2

PART NO.	NOM. SHAFT DIA. (in.)	LOAD (lbf)* MAX/SYSTEM	DIMENSION (inches)					PILLOW BLOCK**
			A ±.001	B	B2	C2	D	
113-08-TXX	1/2	700	0.687	2.00	3.25	3.50	1.25	TEP-8
113-12-TXX	3/4	1,624	0.937	2.75	4.50	4.50	1.75	TEP-12
113-16-TXX	1	2,900	1.187	3.25	5.50	6.00	2.19	TEP-16
113-24-TXX	1-1/2	5,504	1.750	4.75	8.00	9.00	3.25	TEP-24

* Based on horizontal load, equally distributed to each bearing with a travel life of 2 million inches. ** See pages 231-232 for details. XX = shaft length - see page 241.

PRECISION LINEAR SLIDE SYSTEMS TECHNICAL DATA

SERIES 123: DOUBLE SHAFT END SUPPORTED SYSTEM WITH CARRIAGE

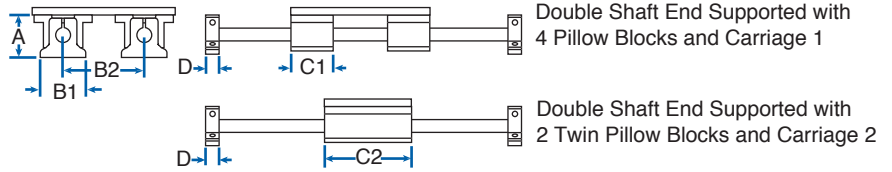
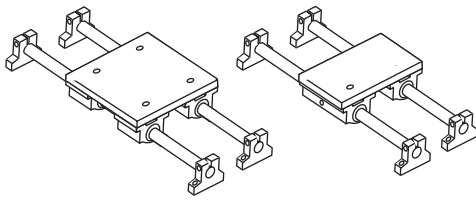

DOUBLE SHAFT END SUPPORTED WITH 4 PILLOW BLOCKS AND CARRIAGE 1

PART NO.	NOM. SHAFT DIA. (in.)	LOAD (lbf)* MAX/SYSTEM	DIMENSION (inches)					PILLOW BLOCK**	END SUPPORT*
			A ±.003	B2	B1	C1	D		
123-08-SXX	1/2	700	1.687	3.25	2.00	1.69	0.63	XEP-8	NSB-8
123-12-SXX	3/4	1,624	2.187	4.50	2.75	2.06	0.75	XEP-12	NSB-12
123-16-SXX	1	2,900	2.687	5.50	3.25	2.81	1.00	XEP-16	NSB-16
123-24-SXX	1-1/2	5,504	3.750	8.00	4.75	4.00	1.25	XEP-24	NSB-24

DOUBLE SHAFT END SUPPORTED WITH 2 TWIN PILLOW BLOCKS AND CARRIAGE 2

PART NO.	NOM. SHAFT DIA. (in.)	LOAD (lbf)* MAX/SYSTEM	DIMENSION (inches)					MAX. STROKE LENGTH (in.)	PILLOW BLOCK**	END SUPPORT*
			A ±.003	B2	B1	C2	D			
123-08-TXX	1/2	700	1.687	3.25	2.00	3.50	0.63	L-(4.75)	TEP-8	NSB-8
123-12-TXX	3/4	1,624	2.187	4.50	2.75	4.50	0.75	L-(6.00)	TEP-12	NSB-12
123-16-TXX	1	2,900	2.687	5.50	3.25	6.00	1.00	L-(8.00)	TEP-16	NSB-16
123-24-TXX	1-1/2	5,504	3.750	8.00	4.75	9.00	1.25	L-(11.50)	TEP-24	NSB-24

* Based on horizontal load, equally distributed to each bearing with a travel life of 2 million inches. ** See pages 231-232 for details. XX = shaft length - see page 241.

SERIES 133: DOUBLE SHAFT FULLY SUPPORTED SYSTEM WITH CARRIAGE

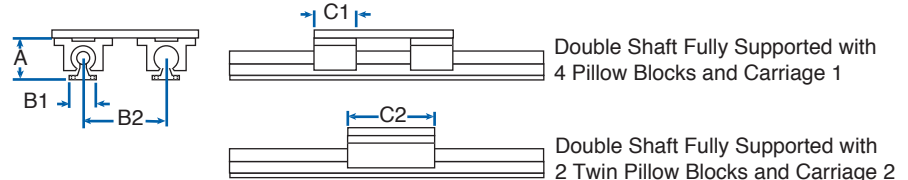
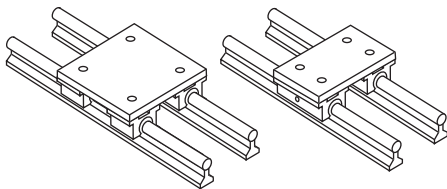

DOUBLE SHAFT FULLY SUPPORTED WITH 4 PILLOW BLOCKS AND CARRIAGE 1

PART NO.	NOM. SHAFT DIA. (in.)	LOAD (lbf)* MAX/SYSTEM	DIMENSION (inches)				PILLOW BLOCK**
			A ±.003	B1	B2	C1	
133-08-SXX	1/2	608	1.812	1.50	3.25	1.69	XEP-8-OPN
133-12-SXX	3/4	1,584	2.437	1.75	4.50	2.06	XEP-12-OPN
133-16-SXX	1	2,844	2.937	2.13	5.50	2.81	XEP-16-OPN
133-24-SXX	1-1/2	5,384	4.250	3.00	8.00	4.00	XEP-24-OPN

DOUBLE SHAFT FULLY SUPPORTED WITH 2 TWIN PILLOW BLOCKS AND CARRIAGE 2

PART NO.	NOM. SHAFT DIA. (in.)	LOAD (lbf)* MAX/SYSTEM	DIMENSION (inches)				PILLOW BLOCK**
			A ±.003	B1	B2	C2	
133-08-TXX	1/2	608	1.812	1.50	3.25	3.50	TEP-8-OPN
133-12-TXX	3/4	1,584	2.437	1.75	4.50	4.50	TEP-12-OPN
133-16-TXX	1	2,844	2.937	2.13	5.50	6.00	TEP-16-OPN
133-24-TXX	1-1/2	5,384	4.250	3.00	8.00	9.00	TEP-24-OPN

* Based on horizontal load, equally distributed to each bearing with a travel life of 2 million inches. ** See pages 231-232 for details. XX = shaft length - see page 241.



**SERIES 212: DOUBLE SHAFT END SUPPORTED SYSTEM
WITH BALL SCREW ASSEMBLY AND CARRIAGE**

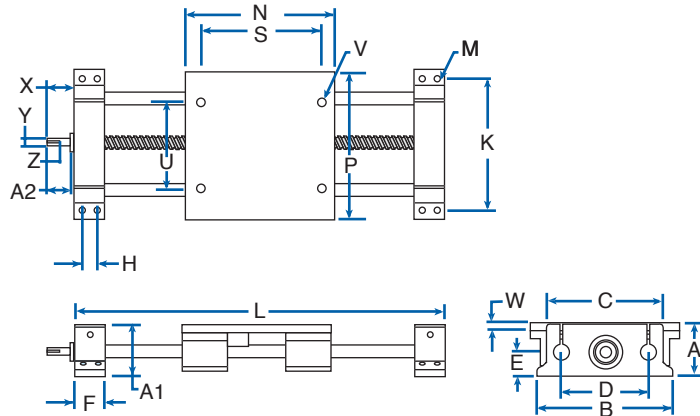
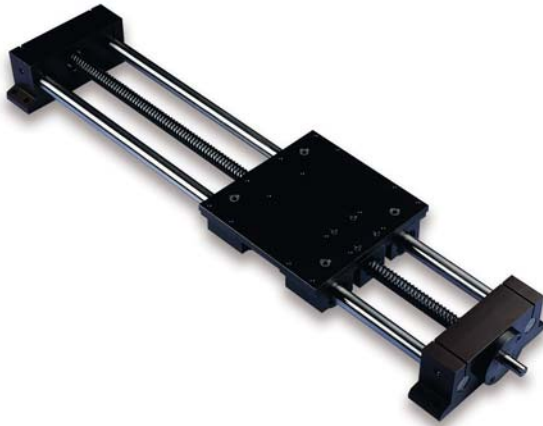

BENEFITS

- Adaptable to any drive system
- Flexible design
- Use where end supported systems are needed
- Pre-aligned, easy installation

COMPONENTS

- 4 Linear bearing pillow blocks
- 2 Integrated end supports
- 2 HG linear shafts
- 1 carriage
- 1 ball screw assembly

PRECISION LINEAR SLIDE SYSTEMS TECHNICAL DATA

DOUBLE SHAFT END SUPPORT SYSTEM WITH BALL SCREW ASSEMBLY AND CARRIAGE

PART NO.	NOM. SHAFT DIA.	LOAD (lbf)*	BALL SCREW DIA.**	DIMENSION (inches)											MIN. "L" DIMENSION (in.)
				A ± .003	A1	B	C	D	E	F	H ±.010	K ±.010	M		
													BOLT	HOLE	
212-08-LXX	1/2	700	1/2	2.187	2.38	5.30	4.25	3.25	1.125	1.50	.75	4.80	#8	.19	TRAVEL+8.50
212-12-LXX	3/4	1,624	3/4	2.937	2.88	7.20	6.00	4.50	1.500	2.00	1.00	6.70	#10	.22	TRAVEL+11.50
212-16-LXX	1	2,900	1	3.437	3.45	8.75	7.25	5.50	1.750	2.20	1.20	8.00	1/4	.28	TRAVEL+13.40
212-24-LXX	1-1/2	5,504	1-1/2	5.000	4.97	13.00	10.75	8.00	2.500	2.80	1.50	12.00	5/16	.34	TRAVEL+18.60

* Based on horizontal load, equally distributed to each bearing with a travel life of 2 million inches. XX = shaft length - see page 241.

**Refer to page 248 for screw selection.

MOUNTING CARRIAGE TOP FOR 212 & 252

PART NO.	DIMENSION (inches)					
	N	P	S	U	V	W
2X2-08-LXX	5.50	5.50	4.50	3.25	1/4-20	.38
2X2-12-LXX	7.50	7.50	6.00	4.50	5/16-18	.50
2X2-16-LXX	9.00	9.00	7.00	5.50	3/8-16	.50
2X2-24-LXX	13.00	13.00	10.00	8.00	1/2-13	.75

SCREW & SHAFT EXTENSION FOR 212 & 252

PART NO.	DIMENSION (inches)				
	Screw Size	X	Y	Z	A2
2X2-08-LXX	0500-0500 SRT	1.00	.250	.51 x .095	.665
2X2-12-LXX	0750-0200 SRT	1.50	.500	.81 x .140	1.02
2X2-16-LXX	1000-1000 SRT	1.74	.625	1.03 x .188	1.26
2X2-24-LXX	1500-1000 SRT	2.32	.750	1.41 x .188	1.657

SERIES 252 SLIDE SYSTEMS

**SERIES 252: DOUBLE SHAFT FULLY SUPPORTED SYSTEM
WITH END SUPPORTS, BALL SCREW ASSEMBLY AND CARRIAGE**

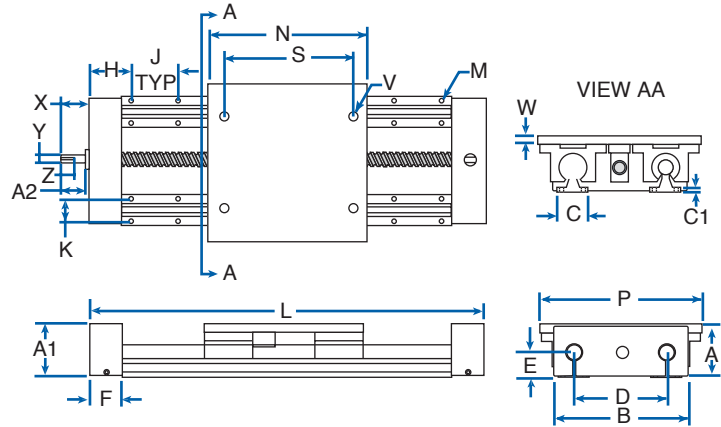

BENEFITS

- Adaptable to any drive system
- Flexible design
- Use where fully supported systems are needed
- Pre-aligned, easy installation

COMPONENTS

- 4 Linear bearing pillow blocks (open)
- 2 Integrated end supports
- 2 HG linear shafts
- 1 carriage, 1 ball screw assembly
- 2 shaft support rails

DOUBLE SHAFT FULLY SUPPORTED SYSTEM WITH END SUPPORTS, BALL SCREW ASS'Y & CARRIAGE

PART NO.	NOM. SHAFT DIA.	LOAD (lbf)*	BALL SCREW	A ±.003	DIMENSION (inches)												MIN. "L" DIMENSION (in.)
					A1	B	D	E	F	C	C1	**H	J±.010	K±.010	M		
		MAX SYSTEM													BOLT	HOLE	
252-08-LXX	1/2	608	.50 - .50	2.187	2.13	4.25	3.25	1.125	1.50	1.50	.187	2.00	4.00	1.00	#6	.17	TRAVEL+8.50
252-12-LXX	3/4	1,584	.75 - .20	2.938	2.75	6.00	4.50	1.500	2.00	1.75	.250	3.00	6.00	1.25	#10	.22	TRAVEL+11.50
252-16-LXX	1	2,844	1.00 - 1.00	3.438	3.25	7.25	5.50	1.750	2.20	2.13	.250	3.00	6.00	1.50	1/4	.28	TRAVEL+13.40
252-24-LXX	1-1/2	5,384	1.50 - 1.00	5.000	4.88	10.75	8.00	2.500	2.80	3.00	.375	4.00	8.00	2.25	3/8	.41	TRAVEL+18.60

*Based on horizontal load, equally distributed to each bearing with a travel life of 2 million inches

** For 18", 30" & 42" std. lengths, H=3.00
If non-standard length "H" is symmetrical

DOUBLE SHAFT SYSTEM STANDARD LENGTH FOR 212 & 252

PART NO.	18"	24"	30"	32"	36"	40"	42"	48"	54"	56"	60"	64"	66"	72"
2X2-08-LXX	■	■	■		■		●	●						
2X2-12-LXX	■	■	■		■		■	■						
2X2-16-LXX	■	■	■		■		■	■	■		■		■	■
2X2-24-LXX		■		■		■		■		■		■		■

● System 252 only

PRECISION LINEAR SLIDE SYSTEMS TECHNICAL DATA



SERIES 302: TWIN SHAFT FULLY SUPPORTED SYSTEM WITH CARRIAGE

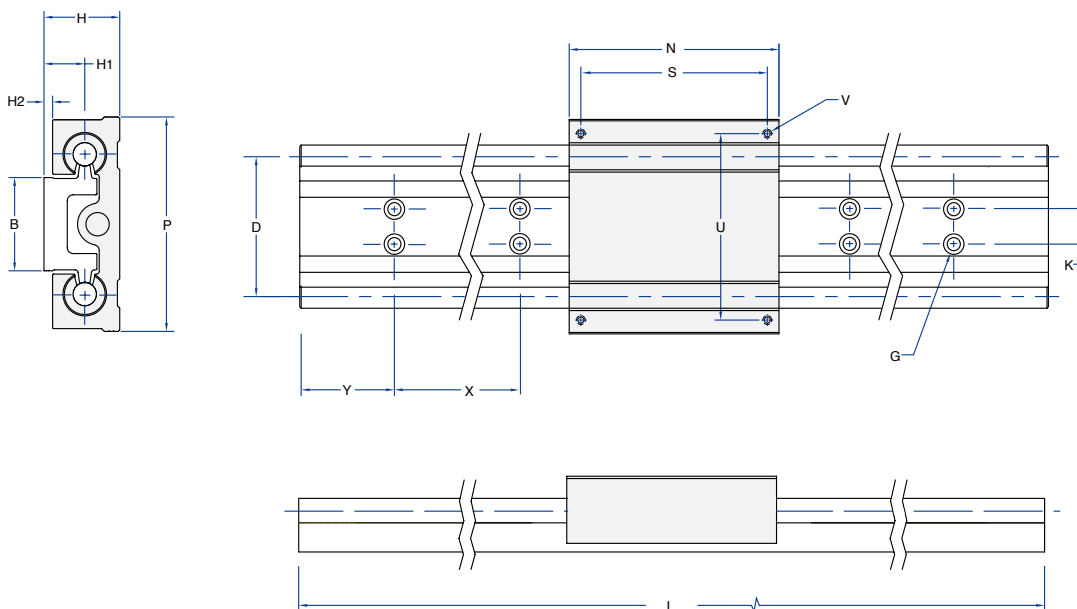

BENEFITS

- Ready-to-use system support
- Fully supported
- Pre-aligned for accuracy and ease of use
- Capable of carrying load in every direction and movement about all axes
- Adaptable to any drive system

COMPONENTS

- One integrated rail with two precision shafts
- One carriage with four open ball bearings

TWIN SHAFT FULLY SUPPORTED SYSTEM WITH CARRIAGE

PART NO.	NOM. SHAFT DIA.	B	P	H	N	H1	H2	D	S	U	V	L*		y†	X	K	G for
												min	max				
302-08-LXX	0.5	2	4.6	1.625	4.5	0.875	0.195	3	4	4	#10-32	12	48	2	4	0.75	1/4 BOLT
302-12-LXX	0.75	2.63	6.1	2.125	6	1.125	0.195	4	5.25	5.25	1/4-20	18	72	3	6	1	5/16 BOLT
302-16-LXX	1	3.25	7.6	2.625	7.5	1.375	0.185	5	6.75	6.75	5/16-18	18	96	3	6	1.25	3/8 BOLT

* Length increases by a multiple of "X" up to the maximum length. For longer systems, or systems with non-standard lengths, please inquire. XX=shaft length

† If non-standard length "Y" is symmetrical

PRECISION LINEAR SLIDE SYSTEMS TECHNICAL DATA

**SERIES 312: TWIN SHAFT FULLY SUPPORTED SYSTEM
WITH END SUPPORT, SCREW ASSEMBLY AND CARRIAGE**

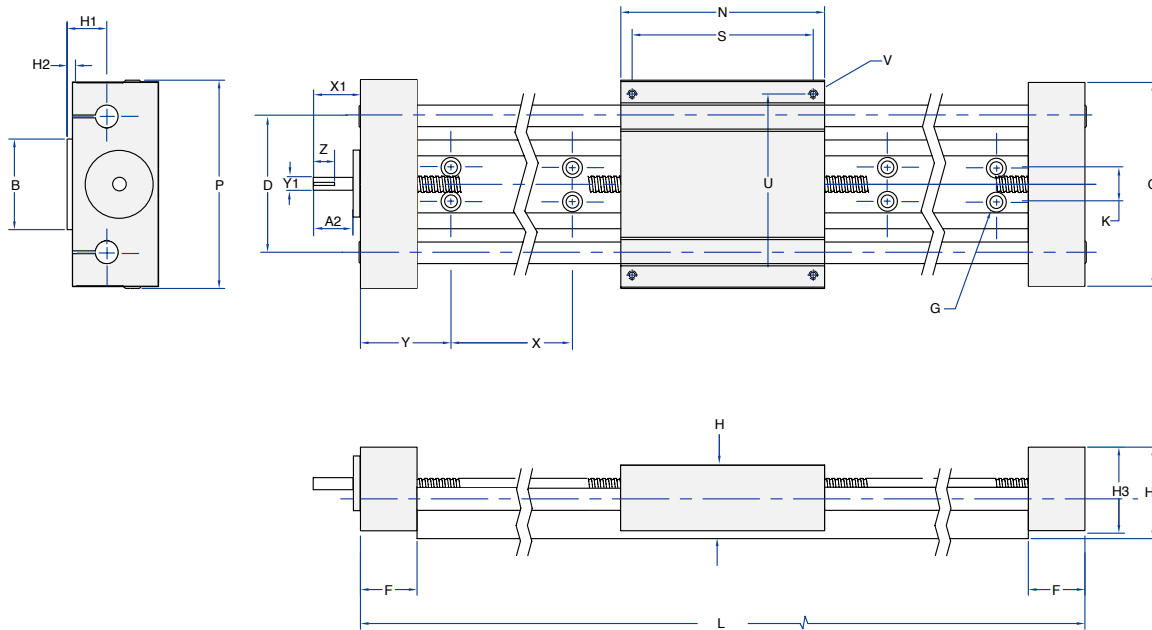

BENEFITS

- Ready-to-use system support
- Fully supported
- Pre-aligned for accuracy and ease of use
- Capable of carrying load in every direction and movement about all axes
- Integrated ball screw drive with standardized motor mount interface

COMPONENTS

- One integrated rail with two precision shafts
- One carriage with four open ball bearings
- One ball screw assembly
- Two end supports with bearings and motor interface.

TWIN SHAFT FULLY SUPPORTED SYSTEM WITH END SUPPORT, SCREW ASS'Y & CARRIAGE

PART NO.	NOM. SHAFT DIA.	BALL* SCREW DIA.	B	P	H	N	H1	H2	H3	H4	C	D	S	U	V	F	L**		Y†	X	K	G for
																	min	max				
312-08-LXX	0.5	3/8	2	4.6	1.625	4.5	0.875	0.195	1.9	2.02	4.5	3	4	#10-32	2	1.25	12	48	2	4	0.75	1/4 BOLT
312-12-LXX	0.75	1/2	2.63	6.1	2.125	6	1.125	0.195	2.37	2.62	6	4	5.25	1/4-2	3	1.5	18	72	3	6	1	5/16 BOLT
312-16-LXX	1	3/4	3.25	7.6	2.625	7.5	1.375	0.185	3.37	3.49	7	5	6.75	5/16-18	3	2	18	96	3	6	1.25	3/8 BOLT

XX=shaft length "L"

*Refer to page 248 for screw selection.

**Length increases by a multiple of "X" up to the maximum length. For longer systems, or systems with non-standard lengths, please inquire.

† If non-standard length "Y" is symmetrical.

SHAFT EXTENSION FOR 312

PART NO.	DIMENSION (inches)			
	X1	Y1	Z	A2
312-08	0.875	0.186	0.34 x 0.063	0.500
312-12	1.00	0.250	0.51 x 0.095	0.665
312-16	1.50	0.500	0.81 x 0.140	1.02



MM SLIDE™ DOUBLE SHAFT END SUPPORTED SYSTEM WITH SCREW ASSEMBLY AND CARRIAGE

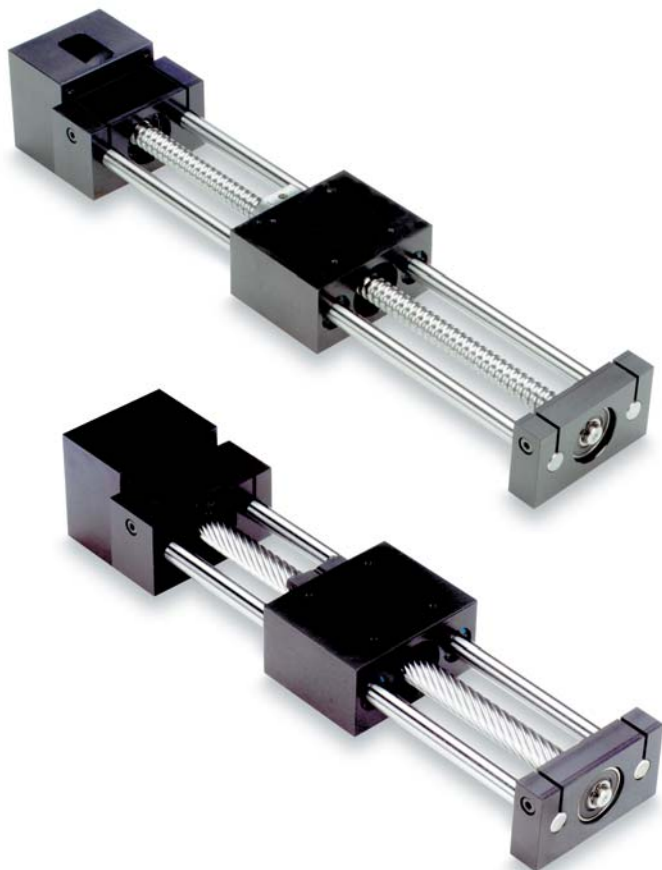

MM SLIDE™ SYSTEM FEATURES:

- The right solution for accurate positioning in limited space applications.
- Lightweight rigid aluminum construction provides high system strength and stiffness.
- Carriage plate includes hole patterns for easy payload integration or X-Y axis mounting.
- A wide variety of metric screw diameters, leads and nut styles are available to accommodate a wide range of performance requirements.
- Adaptable motor mounts provide flexibility in motor/control options.
- MM Slide™ includes one carriage/linear bearing block assembly (contains 4 EXCEL™ linear bearings), two integrated end supports, two HG linear shafts and one lead screw assembly.

PRECISION LINEAR SLIDE SYSTEMS TECHNICAL DATA

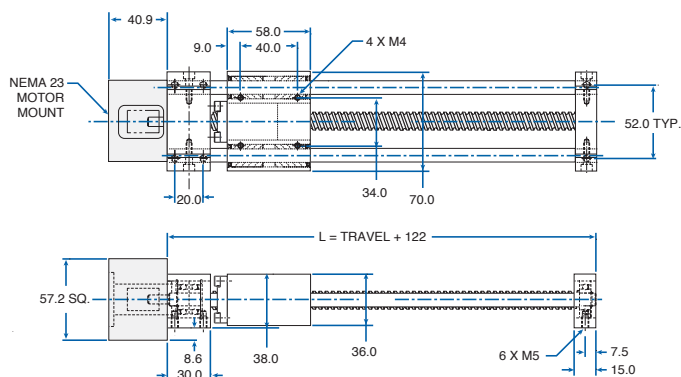

MM SLIDE SCREW SELECTION					
SLIDE PART NO.	Nominal Shaft Dia. (mm)	Load (N)	Metric Screw	Page	L Max. (mm)
012-06-LXX	9.5	1174	Speedy 11 x 60	55	525
			Speedy 13 x 70	58	
			Speedy 14 x 8	59	
			Speedy 14 x 18	59	
			Speedy 14 x 30	59	
			Carry 12 x 4	158	
Carry 12 x 5	158				

XX=OAL [mm]

MOTOR ADAPTERS: SERIES 212, 252 and MM SLIDE™

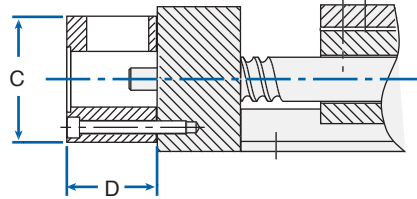
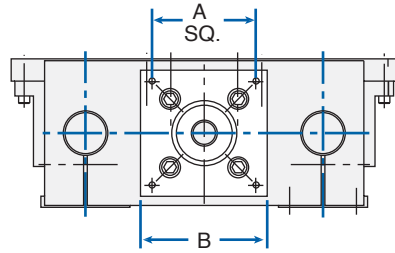

PowerTrax™ Slide System Motor Adapters allow for direct connection of a motor to a slide. Custom configurations are available, contact Nook Industries.

- Coupling is included
- Available for Series 212, 252, 312 and MM Slide™
- Aluminum construction

MOTOR ADAPTORS FOR 212, 252 & 312					
SLIDE PART NO.	Frame Size	DIMENSION (inches)			
		A	B	C	D
-08	23	1.86	2.25	2.25	1.65
-12	23	1.86	2.25	2.25	1.85
-16	34	2.74	3.25	3.25	2.75
-24	42	3.50	4.25	4.25	2.98

MOTOR ADAPTORS FOR MM SLIDE™					
SLIDE PART NO.	Frame Size	DIMENSION (mm)			
		A	B	C	D
012-06	23	47.25	57.2	57.2	40.9

Contact Nook Industries for additional sizes.

BELLOW BOOTS: SERIES 212 and 252

PowerTrax™ Slide System Bellows Boots protect slide components from contaminants. Custom configurations are available, contact Nook Industries, Inc.

- Available for Series 212 and 252
- PVC coated nylon
- Boot is fastened to the end blocks and carriage plate with hook and loop fasteners.

NOTE: Travel must be adjusted to accommodate retracted boot. Calculation per each boot is:
Retracted Boot = ("Travel" x .14")+.25

EXAMPLE 212-08-LXX with 24" Travel:

"L" = (Travel + 8.5") + Ret. Boot + Ret. Boot
39.7" = (24" + 8.5") + 3.6" + 3.6"

(See page 228-229 for 212 and 252 Series min "L" dimension.)

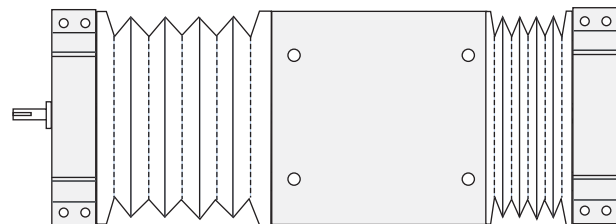



METRIC - CLOSED BEARINGS



- Designed for use on end supported PowerTrax™ HG “M” shafting.
- Bearings are available with or without shaft seals.

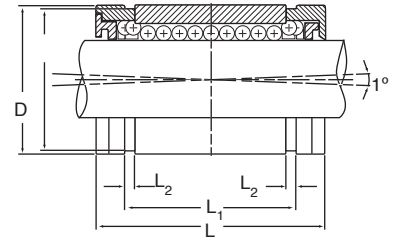
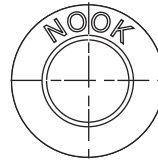

Nominal Shaft Dia.	EXCEL™ Without Seal	EXCEL™ With Seal	No. of Ball Circuits	Housing Bore Dia. D	D ₁	L	L ₁	L ₂	Dynamic Load C (N)		Static Load C ₀ (N)
									Normal	Maximum	
10mm	XLMC10	XLMC10UU	5	19.06/19.03	18	29	21.7	1.35	500	575	390
12mm	XLMC12	XLMC12UU	5	22.08/22.03	21	32	22.7	1.35	650	750	520
16mm	XLMC16	XLMC16UU	5	26.10/26.03	24.9	36	24.7	1.35	800	920	630
20mm	XLMC20	XLMC20UU	5	32.10/32.05	30.3	45	31.3	1.65	1500	1560	1250
25mm	XLMC25	XLMC25UU	5	40.10/40.05	38	58	43.8	1.90	2500	2600	2200
30mm	XLMC30	XLMC30UU	5	47.15/47.05	45.5	68	51.8	1.90	3200	3330	2800
40mm	XLMC40	XLMC40UU	5	62.15/62.05	59	80	60.4	2.20	5500	5720	4900
50mm	XLMC50	XLMC50UU	5	75.20/75.05	72	100	77.4	2.70	8600	8940	7100

METRIC - OPEN BEARINGS



- Designed for use on fully supported shafting.
- Longitudinal section equal to one ball circuit removed for support rail clearance.
- Standard bearing includes shaft seals.

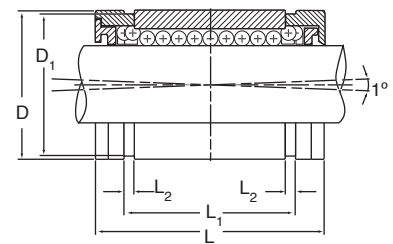

Nominal Shaft Dia.	EXCEL™ With Seal	No. of Ball Circuits	Housing Bore Dia. D	D ₁	L	L ₁	L ₂	E	Dynamic Load C (N)	Static Load C ₀ (N)
12mm	XLMN12UU	4	22.08/22.03	21	32	22.7	1.35	6.5	750	600
16mm	XLMN16UU	4	26.10/26.03	24.9	36	24.7	1.35	9.0	920	730
20mm	XLMN20UU	5	32.10/32.05	30.3	45	31.3	1.65	9.0	1560	1300
25mm	XLMN25UU	5	40.10/40.05	38	58	43.8	1.90	11.5	2600	1290
30mm	XLMN30UU	5	47.15/47.05	45.5	68	51.8	1.90	14.0	3300	2910
40mm	XLMN40UU	5	62.15/62.05	59	80	60.4	2.20	19.5	5720	5100
50mm	XLMN50UU	5	75.20/75.05	72	100	77.4	2.70	22.5	8940	7380

EXCEL™ METRIC SELF-ALIGNING BEARINGS AND PILLOW BLOCKS TECHNICAL DATA



**EXCEL™ PILLOW BLOCKS:
SINGLE & TWIN CLOSED**

**METRIC EXCEL™
BEARINGS**

METRIC - CLOSED SINGLE PILLOW BLOCKS



- Contains a single sealed EXCEL™ Bearing.
- Designed for use on end supported PowerTrax™ HG “M” shafting.

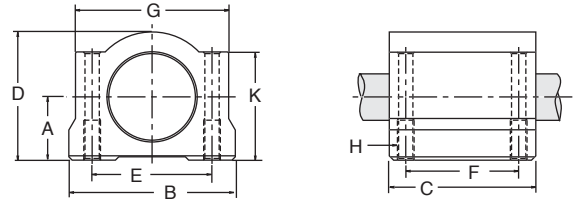

Nominal Shaft Diameter	EXCEL™ Part No.	A ±0.02	B	C	D	E ±0.02	F ±0.02	G	H (Hole)		K	Weight (kg)	LOAD RATING (N)	
									Thread	Hole Dia.			Normal	Maximum
8	XMP-08	11	34	30	22	24	18	32	M4	3.4	18	0.05	500	575
12	XMP-12	15	44	39	30	33	26	41	M5	4.3	24.5	0.09	650	750
16	XMP-16	19	50	44	38.5	36	34	46	M5	4.3	32.5	0.15	800	920
20	XMP-20	21	54	53	41	40	40	52	M6	5.2	35	0.22	1,500	1,560
25	XMP-25	26	76	67	51.5	54	50	68	M8	6.8	41	0.42	2,500	2,600
30	XMP-30	30	78	76	59.5	58	58	72	M8	6.8	49	0.58	3,200	3,300
40	XMP-40	40	102	90	78	80	60	96	M10	8.6	62	1.13	5,500	5,720
50	XMP-50	52	122	110	102	100	80	116	M10	8.6	80	2.12	8,600	8,940

METRIC - CLOSED TWIN PILLOW BLOCKS



- Contains two sealed EXCEL™ Bearings.
- Designed for use on end supported PowerTrax™ HG “M” shafting.

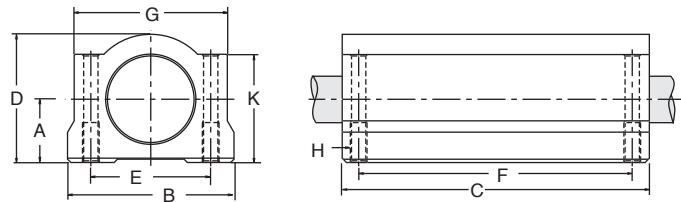

Nominal Shaft Diameter	EXCEL™ Part No.	A ±0.02	B	C	D	E ±0.02	F ±0.02	G	H (Hole)		K	Weight (kg)	LOAD RATING (N)	
									Thread	Hole Dia.			Normal	Maximum
8	TMP-08	11	34	58	22	24	42	32	M4	3.4	18	0.10	1,000	1,150
12	TMP-12	15	44	77	30	33	64	41	M5	4.3	24.5	0.18	1,300	1,040
16	TMP-16	19	50	89	38.5	36	79	46	M5	4.3	32.5	0.30	1,600	1,260
20	TMP-20	21	54	106	41	40	90	52	M6	5.2	35	0.43	3,000	2,500
25	TMP-25	26	76	136	51.5	54	119	68	M8	6.8	41	0.85	5,000	4,400
30	TMP-30	30	78	154	59.5	58	132	72	M8	6.8	49	1.17	6,400	5,600
40	TMP-40	40	102	180	78	80	150	96	M10	8.6	62	2.26	11,000	9,800
50	TMP-50	52	122	230	102	100	200	116	M10	8.6	80	4.38	17,200	14,200

The specifications and data in this publication are believed to be accurate and reliable. However, it is the responsibility of the product user to determine the suitability of Nook Industries products for a specific application. While defective products will be replaced without charge if promptly returned, no liability is assumed beyond such replacement.

**PRECISION HARDENED AND GROUND
METRIC LINEAR SHAFTING**



EXCEL™ METRIC HARDENED AND GROUND SHAFTING TECHNICAL DATA

LINEAR SHAFTING						
PART NUMBER	NOMINAL DIAMETER (mm)	TOLERANCES CLASS "M" DIAMETER (µm)	MAXIMUM LENGTH (m)	MINIMUM DEPTH OF HARDNESS (mm)	WEIGHT PER METER OF LENGTH (kg)	WEIGHT PER INCH OF LENGTH (lb.)
5mm	5	+0/-8	3.0	1.0	.15	.009
8mm	8	+0/-9	3.0	1.0	.39	.022
10mm	10	+0/-9	5.5	1.0	.62	.034
12mm	12	+0/-11	5.5	1.0	.89	.050
16mm	16	+0/-11	5.5	1.7	1.57	.088
20mm	20	+0/-13	5.5	1.7	2.46	.14
25mm	25	+0/-13	5.5	2.7	3.84	.22
30mm	30	+0/-13	5.5	2.7	5.53	.31
40mm	40	+0/-16	5.5	2.7	9.83	.55
50mm	50	+0/-16	5.5	3.7	15.36	.86
60mm	60	+0/-19	5.5	3.7	22.12	1.24
80mm	80	+0/-19	5.5	3.7	39.33	2.21